



UNLIMITED CAD PERFORMANCE DEVELOPED BY ISD

HiCAD Steel Engineering

Version 2026

Railing Configurator

Date of issue: 09/12/2025

isdgroup.com



THE WORLD OF CAD AND PDM SOLUTIONS

TOC

Railing Configurator - Important Notes	5
Requirements	5
Feature log	5
Assembly	5
BOM-relevance of assemblies	7
Assemblies, Usage, BOM-relevance and behaviour in case of drawing derivation	8
Usage for railing segments	8
Coordinate systems of the assemblies	12
Fitting position or Processing position	13
Designation of the vertical rods in the segment views of the workshop drawing	13
Annotation tags of the Railing assembly	13
Railing Configurator - Railings along beams	15
General information	15
General parameters and railing component selection	20
1) Walking line	20
2) Post distribution	21
Automatic post distribution	23
Individual post distribution	27
3) Post	30
4) Handrail	34
5) Infill	35
Infill, between posts	35
Infill, continuous	46
6) Skirting board	49
Connecting the railing components	52
Post - Substructure	53
Post connection, top	55
Post connection, lateral	62
Connection from bottom	69
Connection from bottom with flat steels	70
Lateral connection with flat steels	72
Corner post connection	74
Post - Handrail	78
Handrail - Handrail	82
Skirting board - Skirting board	86
Railing Configurator - Process Railing	91
Multi-Storey Stairs + Railings with Equidistant Posts	93
Step 1: Railing for Staircase 2, left stringer	99
Step 2 - Staircase 1, left stringer	106
Step 3: Staircase 3, left stringer	109

Step 4: Staircase 2, right stringer	110
Step 5: Staircase 1, right stringer	111
Step 6: Staircase 3, right stringer	111
Railing Configurator - Railings along Edges	113
Example - Railing with Individual Post Distribution	121

Railing Configurator - Important Notes

Please note the following when using the Railing Configurator, especially when creating workshop drawings for railings:

Requirements

- The drawing must contain a main assembly. If this is not the case, a corresponding message will be displayed. Extensive information on main assemblies can be found in the topics Assemblies, Main Parts and Sub-Parts, Part Drawing or Assembly Drawing and Edit Part/Assembly Structure. If no main assembly exists, the following message will be displayed.

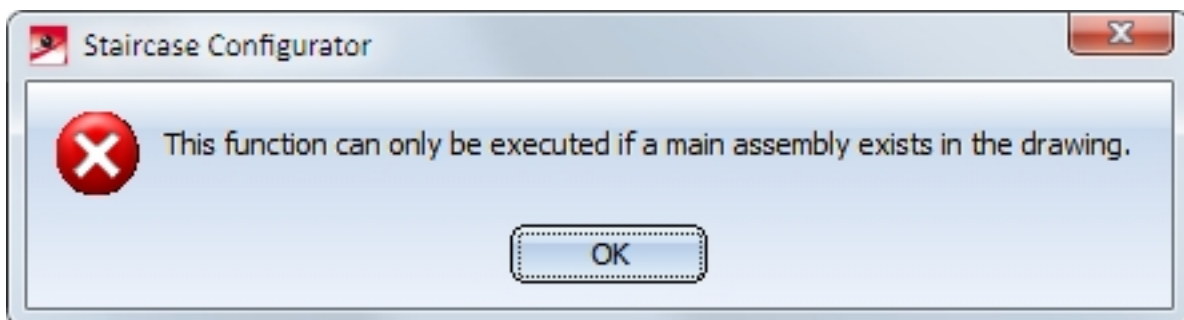

Click **OK** and create a new main assembly and call the function again.

- The beams along which the railing is to be placed must form one continuous "path". Possible are I-, U-, L- and C-beams.
- The axis of the active coordinate system is the direction axis for the posts, which means that the beams must not run parallel to the Z-axis of the active coordinate system. If you are not sure, select **Drawing > Others > World CS**



before calling the Railing Configurator.

- The beams must be straight.

Feature log

Depending on the selected railing function, a feature log item called

Railing along beams or

Railing along edges, respectively,

will be entered into the feature log.

To process an already existing railing, identify one of the railing elements and double-click **Geländer entlang Kanten** or **Geländer entlang Profilen** in the feature log. The Railing Configurator will then be started.

Assembly

An assembly called **Railing** will be created for the railing. This assembly is made up of sub-assemblies called **Segment**, which in turn contain the railing elements of the individual beams. The **Segment** sub-assembly is subdivided into the following sub-assemblies:

- Posts
 - Main part: Pipe (or similar)
 - Further parts

- Handrail
 - Main part: Pipe (or similar)
 - Further parts, e.g. elbows
- Skirting board
 - Main part: L-profile (or similar):
 - Further parts
- Infill
 - Filling parts (Cross-members, Vertical rods, Knee rail, ...)



Important:

If there are several beams in succession that are aligned in the same direction, the railing elements of these beams will be combined into one segment assembly. As a result, continuous hand rails and knee rails will be formed on these beams. The updating and modification of existing railings (before Version 2016 SP2) will still be performed with separate segment assemblies and non-continuous hand rails and knee rails.

Example:

Let us assume that you want to place a railing on beams (1) - (6). The beams (3) and (4) are aligned in the same direction. In this case, the assembly "Railing" will consist of 5 "Segment" sub-assemblies. As a result, the railing elements of beams (3) and (4) have been combined into one railing segment, with continuous hand rails and knee rails.

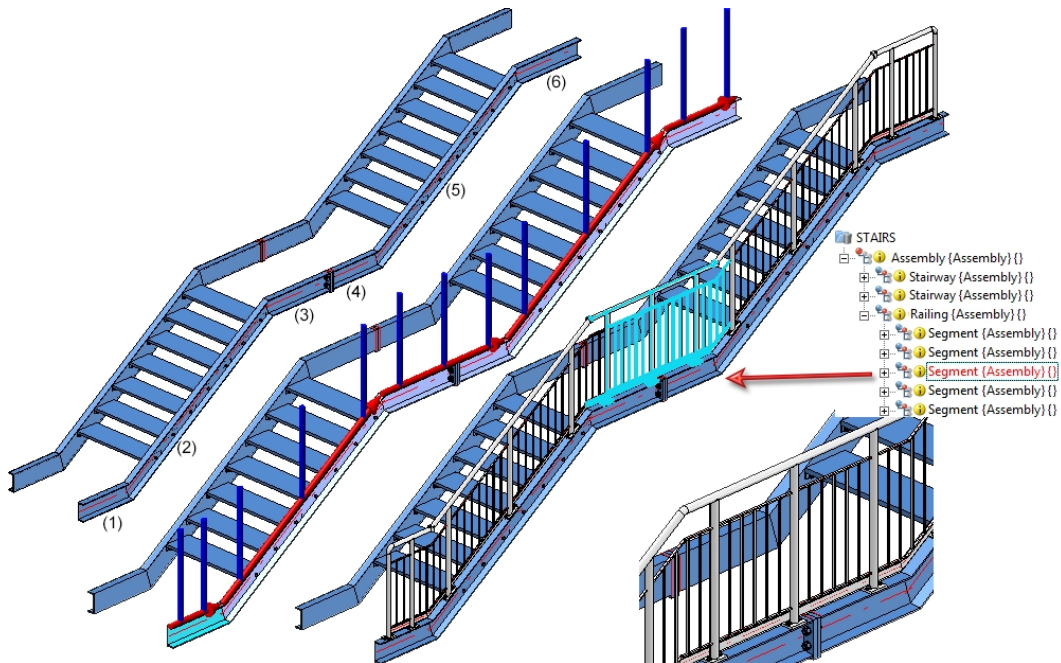

Versions before HiCAD 2016 SP2 would have created 6 "Segment" assemblies, with two separate railing segments for the beams (3) and (4), i.e. one for beam (3) and one for beam (4).

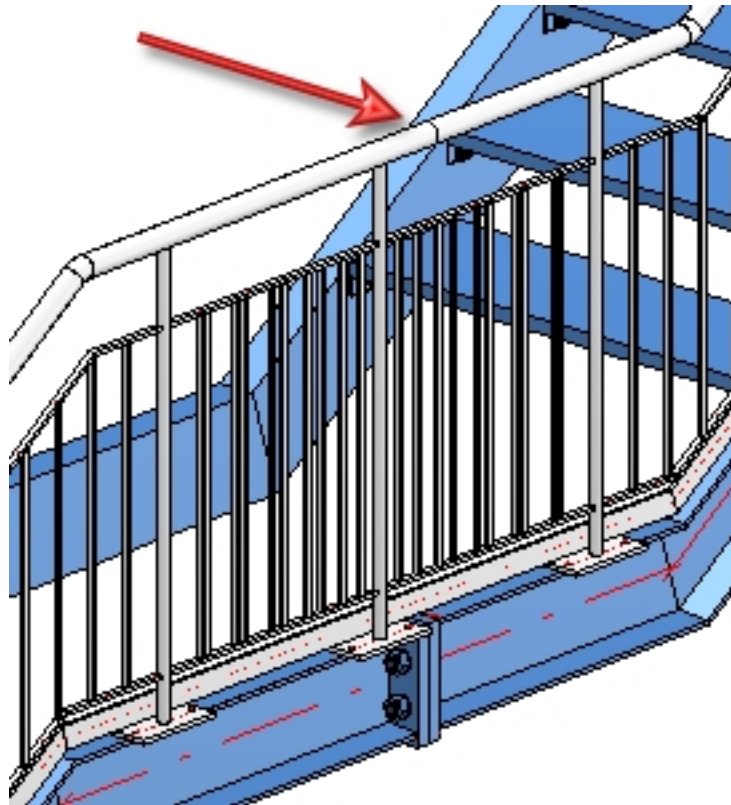

BOM-relevance of assemblies

The BOM-relevance of the assemblies to be created by the Railing Configurator can be set in the Configuration Editor (isdconfigeditor.exe), at **Steel Engineering > Products > Railing**, separately for

- the railing assemblies,
- the segment assemblies, and
- the component assemblies.

The default setting is as follows:

Description	Value	Comment
BOM-relevance of railing assemblies	<input checked="" type="checkbox"/>	Set BOM-relevance when creating assembly
BOM-relevance of segment assemblies	<input checked="" type="checkbox"/>	Set BOM-relevance when creating assembly
BOM-relevance of component assemblies	<input checked="" type="checkbox"/>	Set BOM-relevance when creating assembly



If you deactivate the BOM-relevance for the component assemblies, no assembly main parts will be defined by the Railing Configurator.

Assemblies, Usage, BOM-relevance and behaviour in case of drawing derivation

Assembly	Usage	BOM-relevant? *	CONFIGKEY	Utilized configuration *	Consider for drawing derivation?
Railing	Railing	Yes	RAILING	RAILING	No
Segment	Railing segment	Yes	RAILINGSEGMENT	RAILINGSEGMENT	Yes
Post	Post	No	POST	POST	No
Assembly main part	Post profile	Yes	POSTPROFILE	DEFAULT (Steel pipes)	Yes
Handrail	Handrail	No	HANDRAIL	STRINGER	No
Assembly main part	Handrail profile	Yes	RAILINGPROFILE	DEFAULT (Hollow profiles)	Yes
Infill	Infill	Yes		FILLING	No
Cross-member	Cross-member	Yes		STRINGER	No
Kneerail	Kneerail	Yes	KNEERAIL	STRINGER	No
Vertical rod	Vertical rod	Yes	WEBMEMBER	DEFAULT (Steel pipes)	Yes
Skirting board	Skirting board	Yes	SKIRTING	STRINGER	No
Assembly main part	Skirting board profile	Yes	SKIRTINGPROFILE	DEFAULT (Flat steel)	Yes

*: ISD default setting when using Steel Engineering configuration

The configurations for railings created via drawing derivation are stored in the Configuration Editor (isd-configeditor.exe) at **Automatic drawing derivation > Production drawing > Usage-dependent**. The dimensioning rules for the railing segments can be found at the respective **Set of dimensioning rules** entry, e.g. **Automatic drawing derivation > Production drawing > Usage-dependent > RAILING > Set of dimensioning rules**.

Usage for railing segments

In automatic drawing derivation, the usage RAILINGSEGMENT has been used up to now for the dimensioning of railing segments created by the Railing Configurator. However, there is often the wish to dimension the railing segments differently for different railing types, for example, for segments with glass infill or segments with knee rail infill, etc.

To achieve this, corresponding usages must be defined as well as associated configurations whose name contains the expression RAILINGSEGMENT, e.g. GLASS_RAILINGSEGMENT or KNEEL_RAILINGSEGMENT.

To do this, proceed as follows:

1. You define the desired usages with the Catalogue Editor at **Factory standards > Usage > Civil Engineering > Steel Engineering > Railing**, e.g.

	ID	MOD	STATUS	Designation	CONFIGKEY
	1	4	▶	Skirting board	SKIRTING
	2	12	▶	Skirting board profile	SKIRTINGPROFILE
	3	6	▶	Rod	WEBMEMBER
	4	7	▶	Infill	FILLING
	5	8	▶	Railing	RAILING
	6	9	▶	Railing segment	RAILINGSEGMENT
	7	14	▶	Railing segment (oblique)	STAIR_RAILINGSEGMENT
	8	16	▶	Railing segment Glass	GLAS_RAILINGSEGMENT
	9	17	▶	Railing segment Knee	KNIE_RAILINGSEGMENT
	10	13	▶	Glass	GLASSPANE
	11	5	▶	Cross-member	STRINGER
	12	1	▶	Handrail	HANDRAIL
	13	10	▶	Handrail profile	RAILINGPROFILE
	14	3	▶	Knee rail	KNEERAIL
	15	2	▶	Post	POST
	16	11	▶	Post profile	POSTPROFILE
	17	15	▶	Wall hand rail	WALLHANDRAIL

2. In the Configuration Manager, you derive the new usages GLAS_RAILINGSEGMENT and KNIE_RAILINGSEGMENT from the usage RAILINGSEGMENT, for example, at **Automatic drawing derivation > Production drawing > Usage-dependent**. (The names must correspond to the entry in the CONFIGKEY column of the above table in the Catalogue Editor). To derive, right-click on **Template** and select **Derive structure**. Instead of **_MASTER_**, enter the name of the new usage, e.g. GLAS_RAILINGSEGMENT, activate the checkbox **Copy values** and select **RAILINGSEGMENT** as the template.

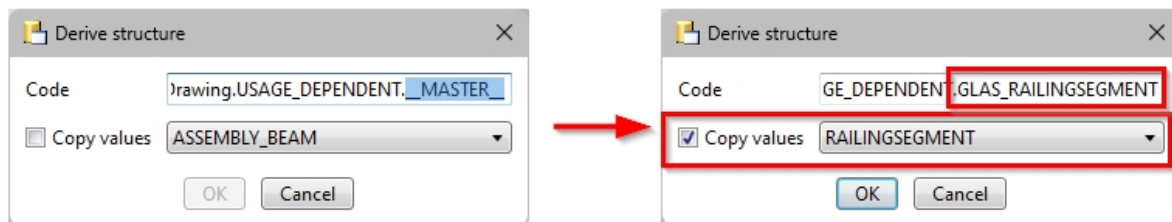

3. With **OK**, the new usage is created.

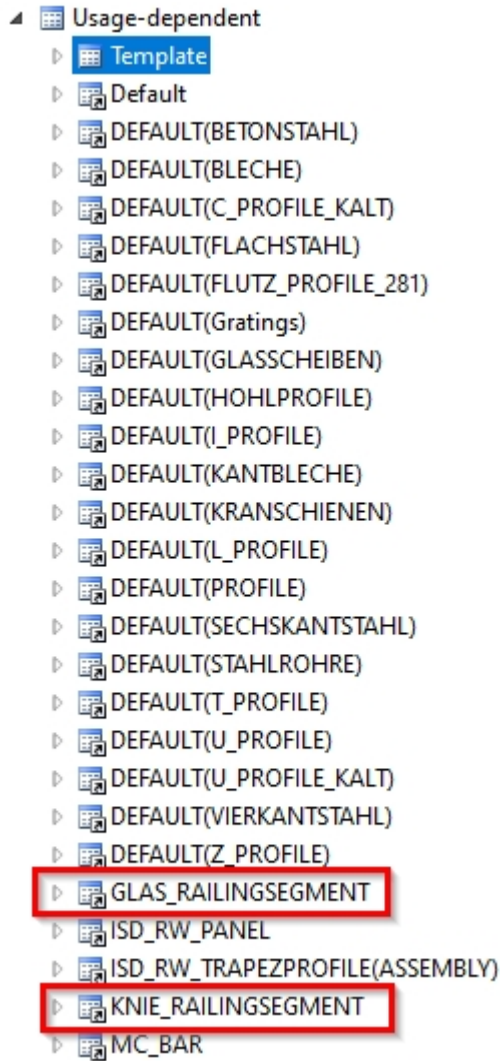

- The new usages must now be assigned. To do this, open the entry **Usage assignment**, activate a row in the **Railing** area and click on **New**. A new row is created. In the column, select the name of the usage in the selection list, e.g. **Railing segment Glass**, in the second column the part type and in the third column the name of the template, e.g. GLAS_RAILINGSEGMENT. Now you can define the dimensioning rules for the new types of use in HiCAD with the dimensioning rule editor. To do this, open the corresponding templates, e.g. **GLAS_RAILINGSEGMENT**, adjust the dimensioning rules accordingly and save the template..

During automatic drawing derivation, these templates are then taken into account for the railing segments to which you have assigned the corresponding usage, e.g.

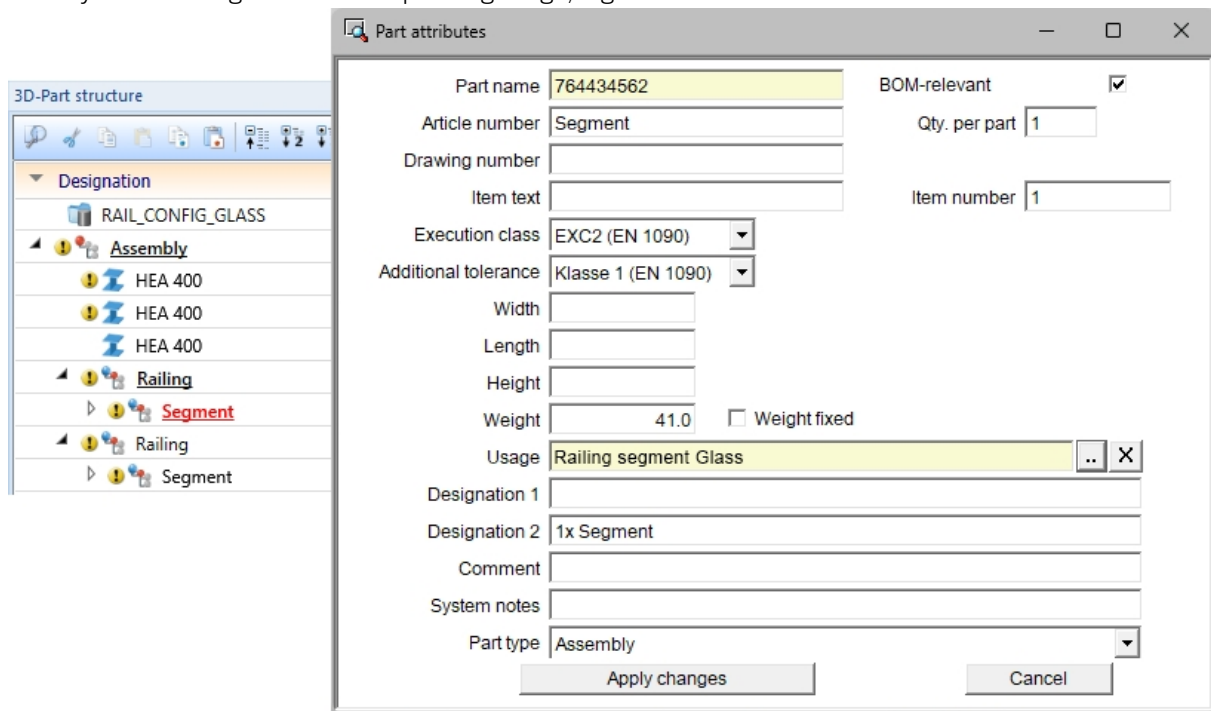

A simple example:

Based on the above procedure, two new usages **Railing segment Glass** and **Railing segment Knee** as well as the corresponding templates **GLAS_RAILINGSEGMENT** and **KNIE_RAILINGSSEGMENT** have been defined. The dimensioning rule sets of these templates were changed and differed.

The example construction contains two railing segments - one with knee rails and one with a glass infill. The corresponding new usages were assigned to these segments.

3D-Part structure		
Designation	I...	Comment
RAIL_CONFIG_GLASS		
Assembly		Assembly
HEA 400	4	I-beam with parallel...
HEA 400	3	I-beam with parallel...
Railing	2	Assembly
Segment	1	Assembly
Railing	1	Assembly
Segment	1	Assembly

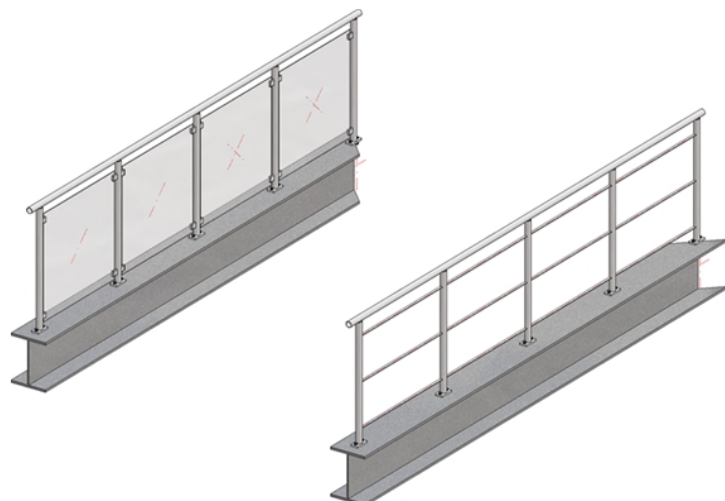

Example of an automatic drawing derivation

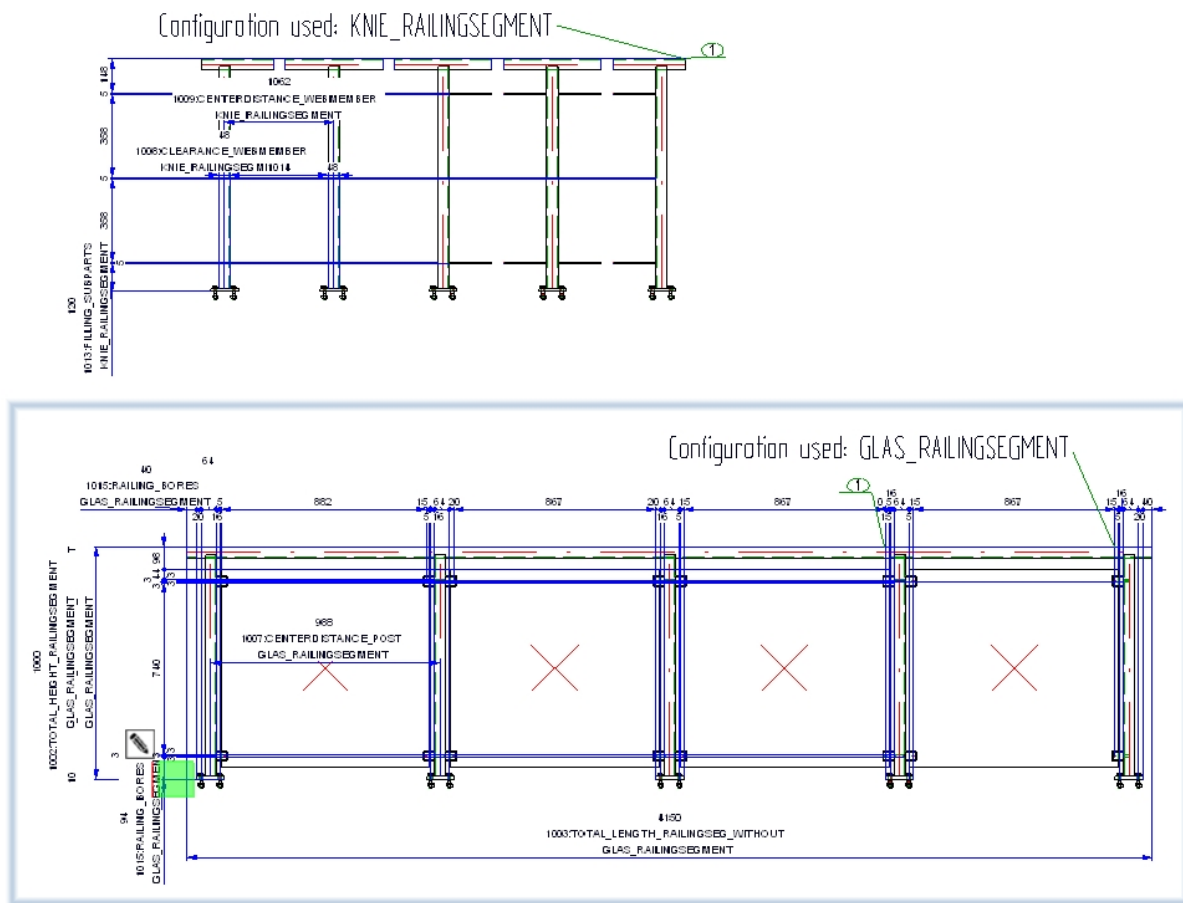

Coordinate systems of the assemblies

The assemblies Railing, Railing segment, Handrail, Post and Filling possess reliable coordinate systems which can be used for the determination of the views and the dimensioning of derived drawings.

At the time of assembly creation, the origin of the assembly coordinate systems is located in the origin of the world coordinate system.

- Railing

The part coordinate system of the railing is selected in such a way that in the first segment is appropriately displayed in the front view of the workshop drawing (Z-axis = Z-axis of the world coordinate system; the X-axis is selected in such a way that the routing direction of the first segment will be in the XZ-plane)
- Railing segment

The part coordinate system is selected in such a way that the segment will be located in the XZ-plane of the Segment assembly. X points in the routing direction.
- Infill

The part coordinate systems of the Infill assemblies are identical with those of the segments.
- Handrail

The part coordinate system of the Railing assembly is identical with that of the segment.
- Skirting board

The part coordinate system of the Skirting board is identical with that of the segments.

- Post

The Z-axis is that of the world coordinate system. The XZ-plane will be selected according to the construction direction of the segment.

Fitting position or Processing position

Railing segments can be displayed in fitting position or in processing position in workshop drawings. The fitting position makes sense for inclined railings, the processing position should be used for railings in X-direction, i.e. with horizontal handrail.

Designation of the vertical rods in the segment views of the workshop drawing

When assigning designations to the vertical rods in the Segment views, only one designation (Item number) will be generated for several identical parts, i.e. identical rods in one view will obtain one designation (item number), while the other parts of the railing will be designated individually.

Annotation tags of the Railing assembly

The main annotation tags of the Railing assembly are defined by the template file WSD_RailingAssembly.FTD. The file contains the Usage and Item number attributes. Sub-part tags are defined by the template PosNummerSTB_Nebenteile.FTD.



Please note that the German or English names (not the key names) of the tree structure are used for references to the Configuration Management!

Railing Configurator - Railings along beams

General information

[Civil Engineering functions docking window > Steel Engineering > Stairs + Railings > Railing > Railing Configurator \(Railings along beams\)](#)

The Railing Configurator, which is part of the HiCAD Steel Engineering module, enables you to configure and insert individual railings along beams, e.g. for staircases created with the Staircase Configurator, or various platforms.

Before using the Railing Configurator, please read the information given in the Railing Configurator - Important Notes topic.

As this function is rather complex, the settings will initially be explained by means of a simple staircase example. How to proceed for multi-storey stairs and railings with equidistant railing posts is explained in a separate example.

First, a railing is to be added to the staircase that has been generated with the Railing Configurator (Stringers: U280 beams). Please note that in this example, the ISD default settings are used.

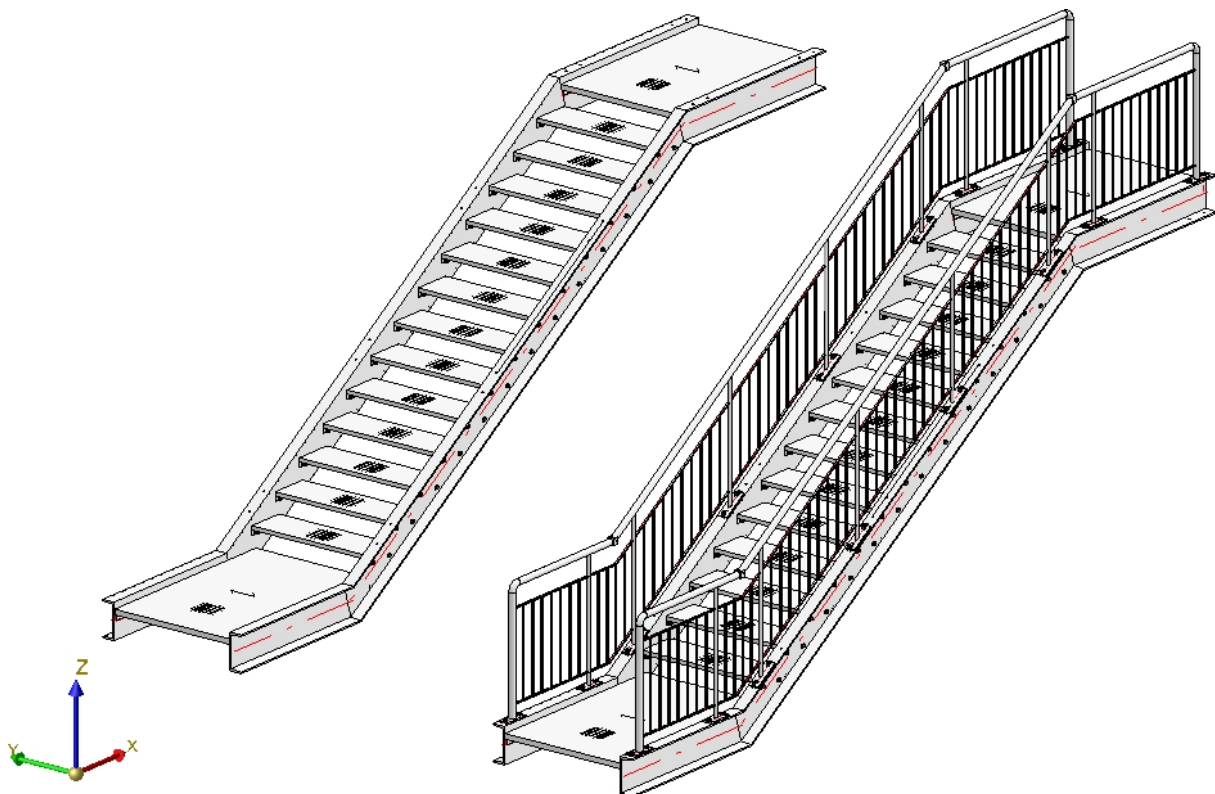

Simple staircase with railing

Before starting the Railing Configurator, please make sure that the coordinate system is aligned correctly. The Railing Configurator aligns the railings to the Z-axis. If you are not sure, select **Drawing > Others > World CS**  to activate the 3-D World CS (=default CS).

After calling the Railing Configurator you will be prompted to identify, one by one, the Steel Engineering beams onto which the railing is to be placed. The "path" that is formed by the beams will define a virtual composite edge that will serve as a guideline for the route of the railing. Posts, handrail, infill and knee rails will then be located on a composite edge running parallel to this guideline, the so-called walking line.

When selecting the beams, please note that the selection point for the first beam is the start point according to which the subsequent division of the railing is based (fixed distance with rest at the beginning or end). For example, in practice, designers follow the walking direction from bottom to top when designing stair railings. The selection point for the next beam determines the direction in which the railing is installed. If the order of the selected beams results in only one possible walking direction of the railing, the selection of the end of a beam is ignored.

In the example shown below, the first beam is selected at point (1), the second beam at point (2). A shows the result before HiCAD 2022 SP1, B the result in HiCAD 2022 SP1.

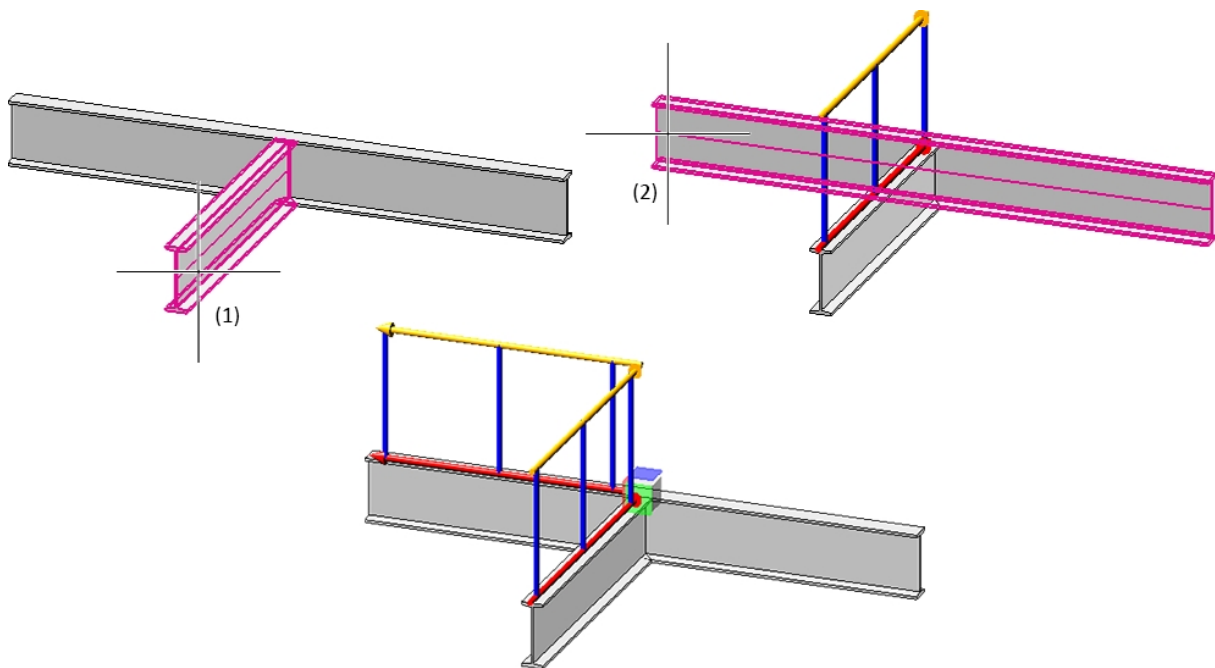

During selection of the beams, the walking line and walking direction will be visualized by means of a red arrow. This walking line determines the height and the fixing position of the railing. The distribution of posts, too, will be visualized according to the last selected settings. As soon as you change the settings in the dialogue window, the preview will be updated.

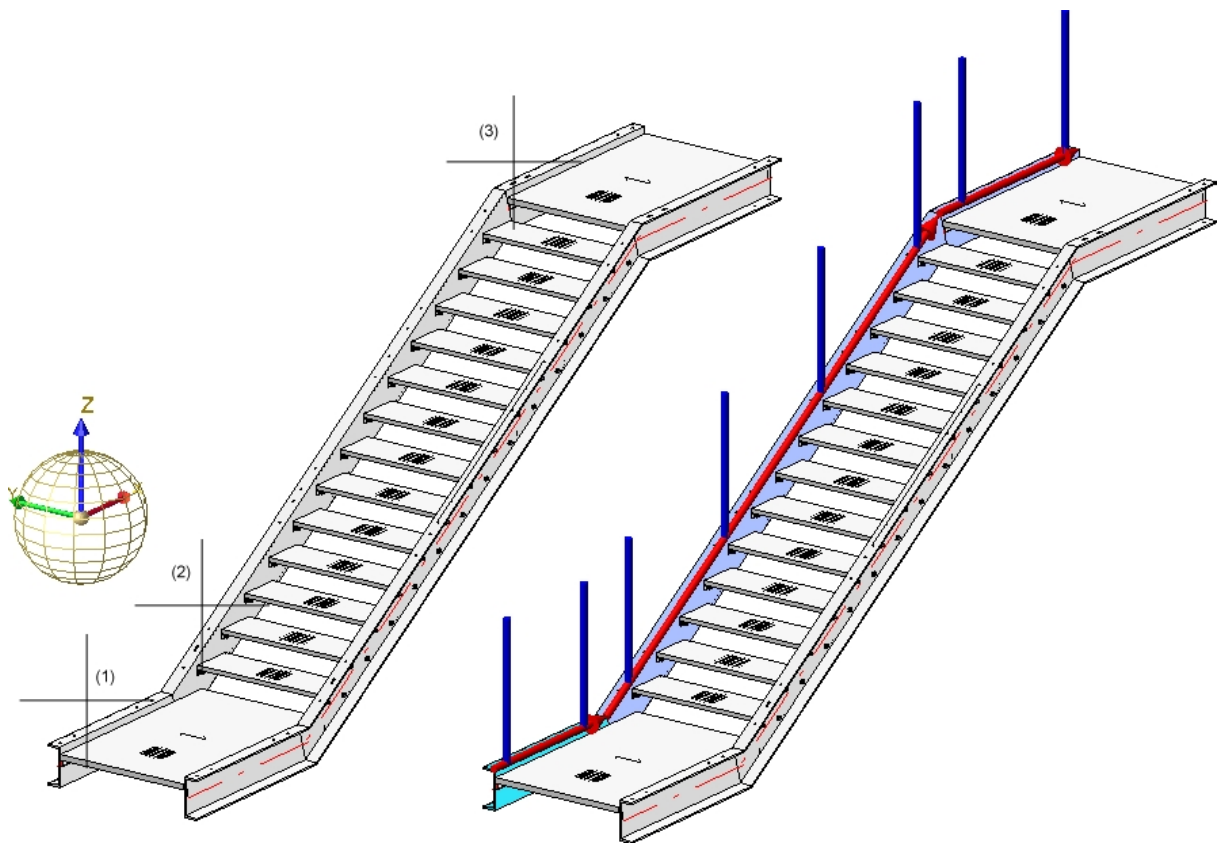



Example, Step 1 - Selection of beams (1), (2) and (3) -> Walking line and direction will be visualized

You end the selection of beams by clicking the middle mouse button. This automatically opens the **Railing Configurator** dialogue window.

Railing Configurator (ISD defaults)

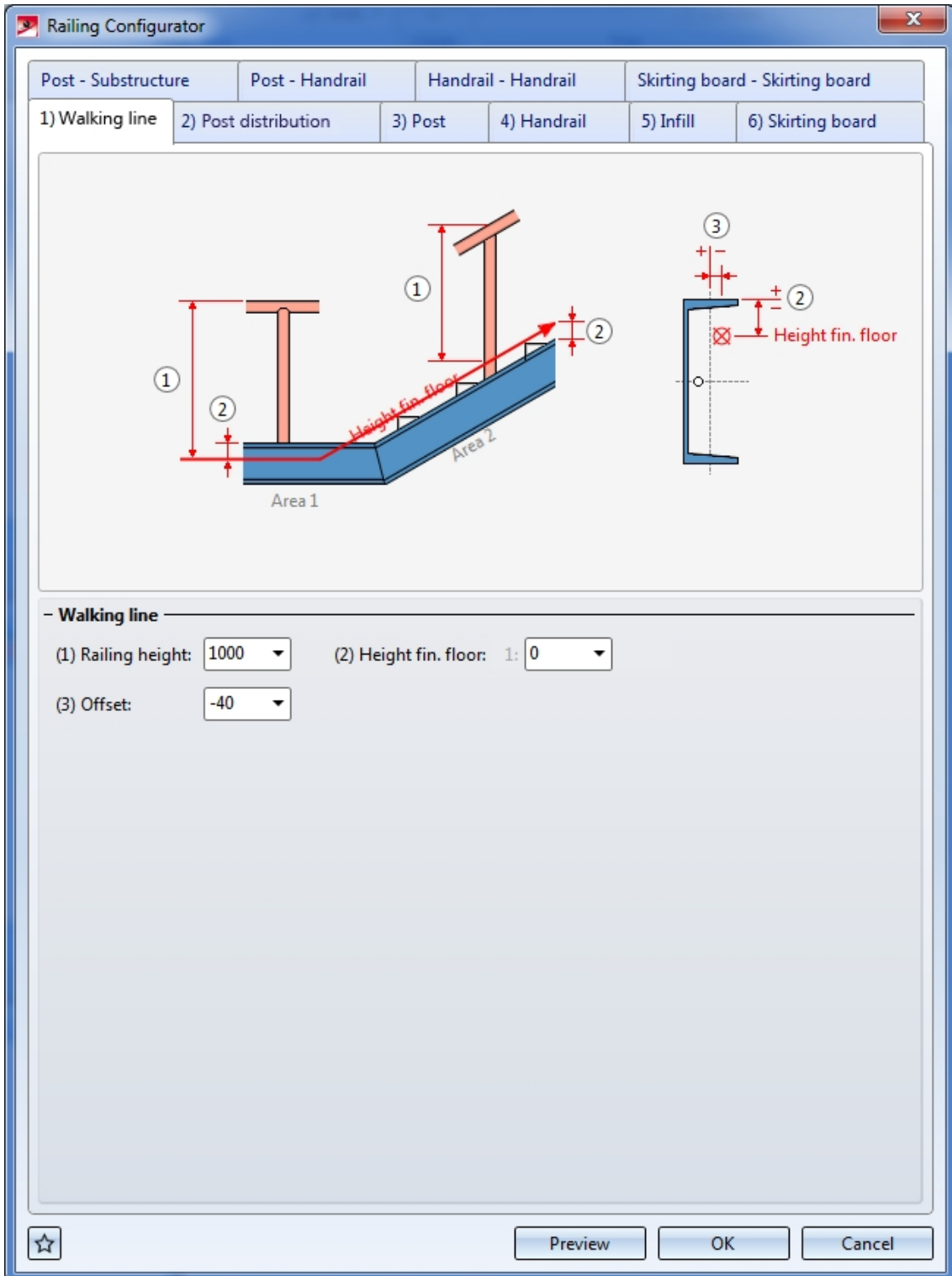

This dialogue window consists of the following tabs:

General parameters and component selection:

- 1) Walking line
- 2) Post distribution
- 3) Post
- 4) Handrail
- 5) Infill
- 6) Skirting board

Parameters for the definition of the railing components:

- Post - Substructure
- Post - Handrail
- Handrail - Handrail
- Skirting board - Skirting board

The settings can be saved as Favourites and reused at any time. At the bottom left of the dialogue window, click the



symbol to activate a menu with Favourites functions. More information about Favourites can be found in the **Manage Favourites** topic of the **HiCAD Basics** Help.

While the window is open, you can display a **Preview** of the railing generated with the current settings by clicking the same-named button. You can use the zoom functions to enlarge or downsize the object on the screen.



Click **OK** to start the generation of the railing. The progress of the generation will be indicated in a progress bar.



Please note:

- All settings specified in the Railing Configurator dialogue window will be saved as defaults and will be shown when you call the Configurator again.
- An assembly called **Railing** will be created for the railing. This assembly in turn consists of sub-assemblies called **Segment**, which contain the railing elements on the individual beams.

If there are several beams in succession that are aligned in the same direction, the railing elements of these beams will be combined into one segment assembly. As a result, continuous hand rails and knee rails will be formed on these beams. The updating and modification of existing railings (before V 2016 SP2) with such areas will still be performed using individual segment assemblies and thus with non-continuous hand rails and knee rails. This also applies to curved beams with equal radius and mid point from HiCAD 2019 2019 SP2, Patch 1 onwards. The updating and modification of existing railings (before Version 2019 SP2, Patch 1) will still be performed with separate segment assemblies and thus with non-continuous hand rails and knee rails.
- A feature log entry called **Railing along beams** will be entered in the feature log.
- Various components and connections belong to a railing, which are all created via Design Variants. The ISD has supplied the corresponding Design Variants for this purpose. If desired, you can also create customized Design Variants for the components. If you have any questions about the procedure, contact our Consulting team.
- To select the variant for a component, just click on the corresponding tab. Select the desired variant from the list-box, click the  icon to directly choose the component from the HiCAD catalogue and specify all required settings.

- In some tabs you can use  and  symbols to open and close input areas.
- The updating of stairs and railings with deleted parts has no longer been possible since HiCAD 2017. However, this only concerns the stairs and railings that have been created with HiCAD 2017 (Version 2200) or newer.
- Railings created with older versions of the Railing Generator (from Version 2101.0 onwards) can be updated or changed if you have subsequently deleted parts that were created by the corresponding variant. However, these deleted parts will be re-created upon updating if these are required due to the parameters and the geometrical situation.
- You can also create curved railings in one plane. However, this is not possible for beams that were placed along composite edges.

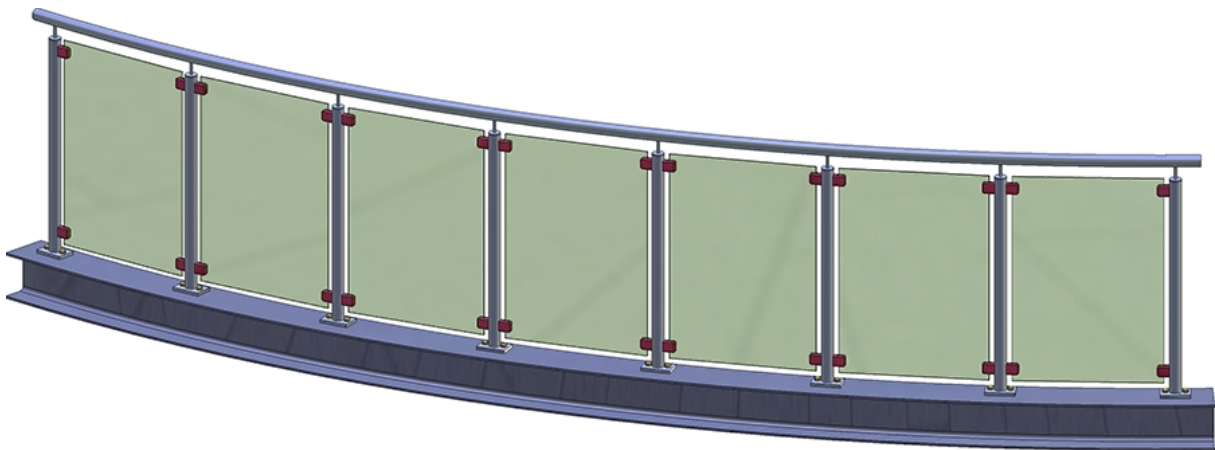

Curved railing, created along a curved beam

General parameters and railing component selection

1) Walking line

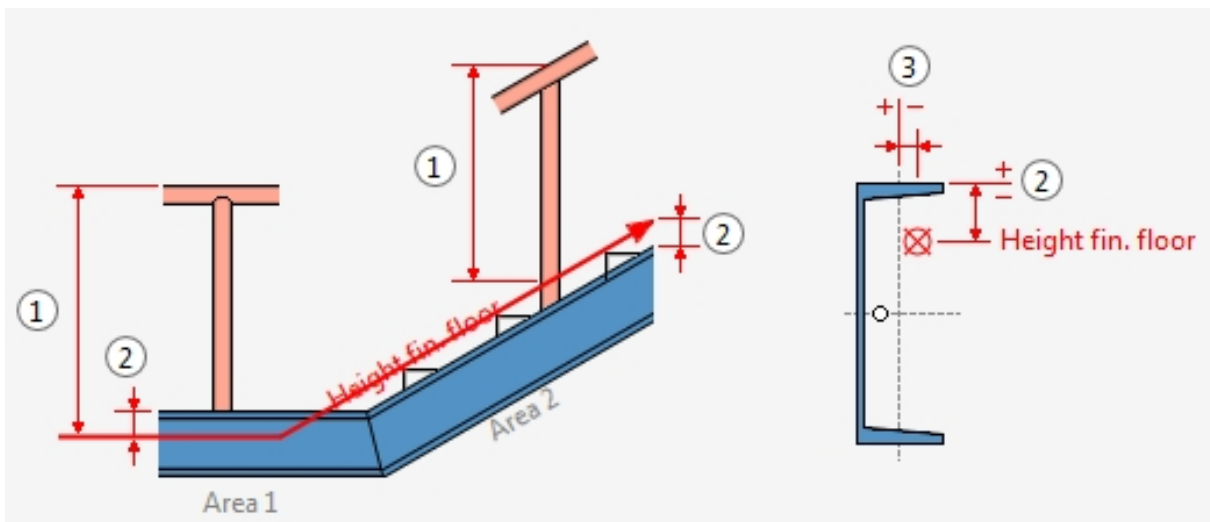

Railing height (1)

This value determines the railing height from the finished floor. This height always refers to the top step corner.

Height fin. floor (2)

This value determines the distance between the upper beam side and the finished floor. If you enter a value greater than 0 or less than 0, the entire walking line will be moved upwards or downwards. Depending on the type of the selected beams you can also specify different heights for the finished floor. For this purpose, the selected beams are subdivided into areas. The first beam belongs to area 1. HiCAD will then check whether the next beam is located in the same plane. If this is the case, it also belongs to area 1. If not, area 2 starts with this beam etc. For each of these areas the value **Height fin. floor** can be specified separately.

Offset (3)

Here you specify the lateral distance to the beam axes - seen in positive direction to the left / negative direction to the right in walking direction (3). Please note that you can also take the values directly from the drawing by right-clicking the input field and selecting **Pick distance**.

2) Post distribution

On this tab you specify which posts are to be created, and how the posts are to be distributed along the walking line. The post distribution can take place automatically or manually.

2) Post distribution

- Distribution of posts

Evenly, with max. dist.

Evenly, with number of posts

Fixed distance, with rest

Patch at start

Patch at end

Distribute patch at both ends

Distance:

Number:

Individual Auto->Individual

- Reference for post distribution

By segments

Across complete walking distance

- Reference for distances

Post axis - Post axis

Clear width

- Create which posts?

Create start post

Create end posts

Create corner posts*

Create transition posts*

- Offset

(4) Corner distance:*

(5) Transition distance:*

(6) Start distance:

(7) End distance:

* Reference for post distribution must be 'By segments'.
The guideline must have a corner or a transition.
Connection to handrail and sub-structure must be constructed manually.

One distinguishes between start post, end post and transition post.

Example with start post (a), transition posts (b) and end posts (c)

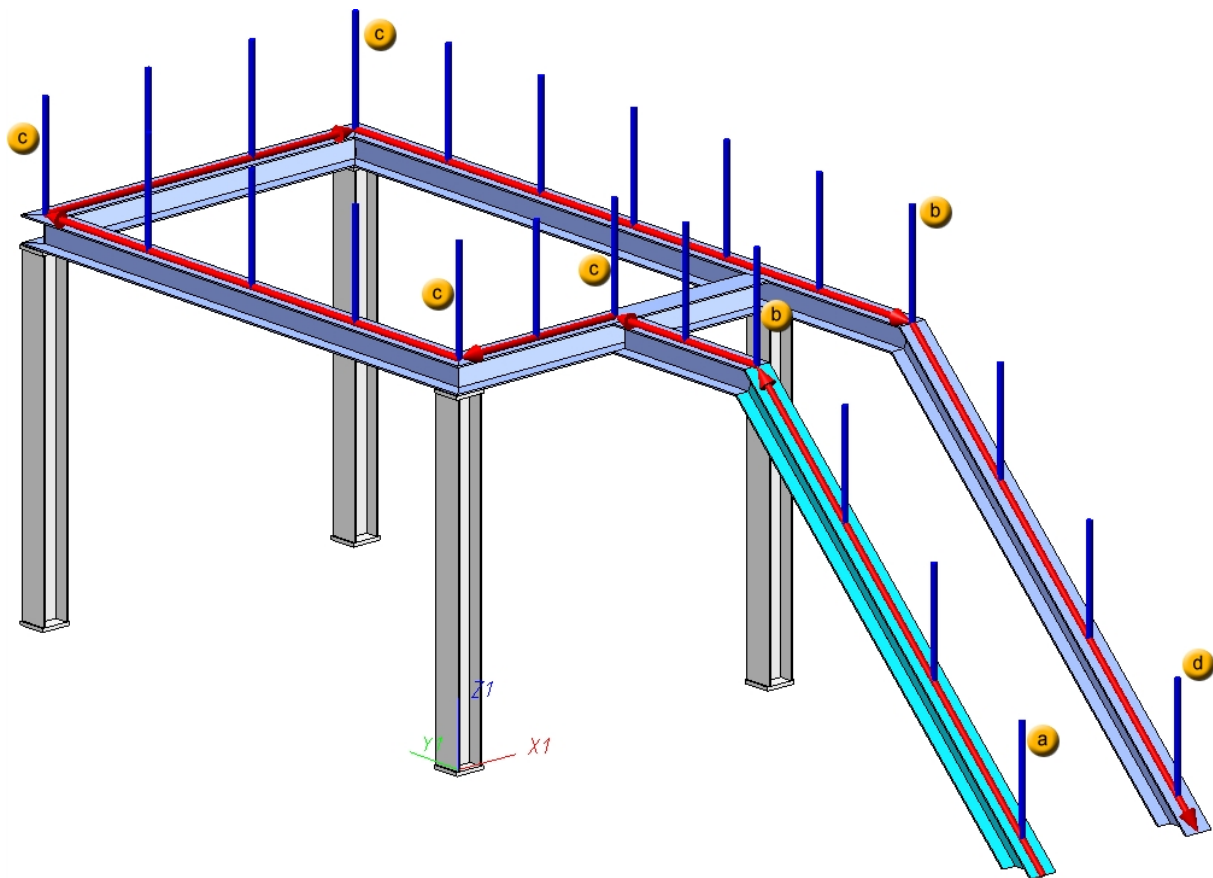

Automatic post distribution

Reference for post distribution

The distribution of the posts can take place by segments or across the complete walking distance. A segment is the length between the virtual axes, i.e. the perpendiculars in the corner points or inflexion points of the red walking line.

The **By segments** setting makes sense for the creation of balcony railings. Here, the posts will be evenly distributed to the corners, and the corner fields are also filled evenly .

On the other hand, the **Across complete walking distance** setting can be useful for the creation on railings on staircases, e.g. for multi-storey staircases and railings with equal post distances.

A segment is the length between the virtual axes (i.e. the perpendiculars in the inflexion points of the red line, pls. see image below), e.g.:

- First segment: From the start of the red line, offset by Dimension 6 to the first axis (First inflexion point)
- Last segment: From the end of the red line, offset by Dimension 7 to the last inflexion point of the red line
- In the stair flight segment, HiCAD calculates the post distances according to the corresponding, specified options (equal post distances or evenly with number of posts), i.e. the "virtual axis" of the red lines - 2x Dimension 5.
- The post distances of Dimension 5 are considered here.

Distribution of posts

■ Evenly, with max. distance

If you select this option, the Start distance (Dimension 6) and the End distance (Dimension 7) will be subtracted from the total length of the walking line. The rest will be distributed in such a way that the distances between the posts will be equal and will not exceed the specified maximum distance. The Transition distance (Dimension 5) will not be considered.

■ Evenly, with number of posts

Here, the calculation length will be divided by the number of posts, with regard to the axis length. The value in the **Distance** field as well as the Transition distance (Dimension 5) will not be considered.

■ Fixed distance, with rest

If you select this option, you need to check whether the remaining rests (patches) are to be located at the start, at the end or on both sides. It is therefore recommended to use "virtual" vertical auxiliary lines during the construction process. For if the railing posts are to be located below one another after completion of the construction, this can be achieved easiest with this option. This means that the specified dimensions will only be used for the active flight of stairs (walking line). In the sketch you can see that the flight of stairs 1 places Dimension 6 at the bottom right (at the start), and Dimension 7 at the left. When you activate the flight of stairs 2, Dimension 6 will be located on the left, and Dimension 7 on the right. This should be taken into account to ensure that the correct distances will be entered. Dimension 5 will not be considered.

When selecting the beams, please note that HiCAD interprets the first selected beam as the start, which the later partitioning of the railing will be based on (fixed distance with rest at the start or end). In practice, engineers mostly use an upstairs walking direction as an orientation.

For the distribution of posts in the image this means:

- The first post will be offset by Dimension 6 with regard to the first axis
- The second post is located before the first inflexion point of the walking line at the distance of Dimension 5.
- The third post is offset by Dimension 5 with regard to the first inflexion point.
- In the stair flight segment, HiCAD calculates the post distances according to the corresponding, specified options (equal post distances or evenly with number of posts), i.e. the "virtual axis" of the red lines - 2x Dimension 5.
- The last but one post is offset by Dimension 5 with regard to the last inflexion point of the walking line.
- The last post has a distance of Dimension 7 from the end of the walking line.

Example: Distribution of posts by segments

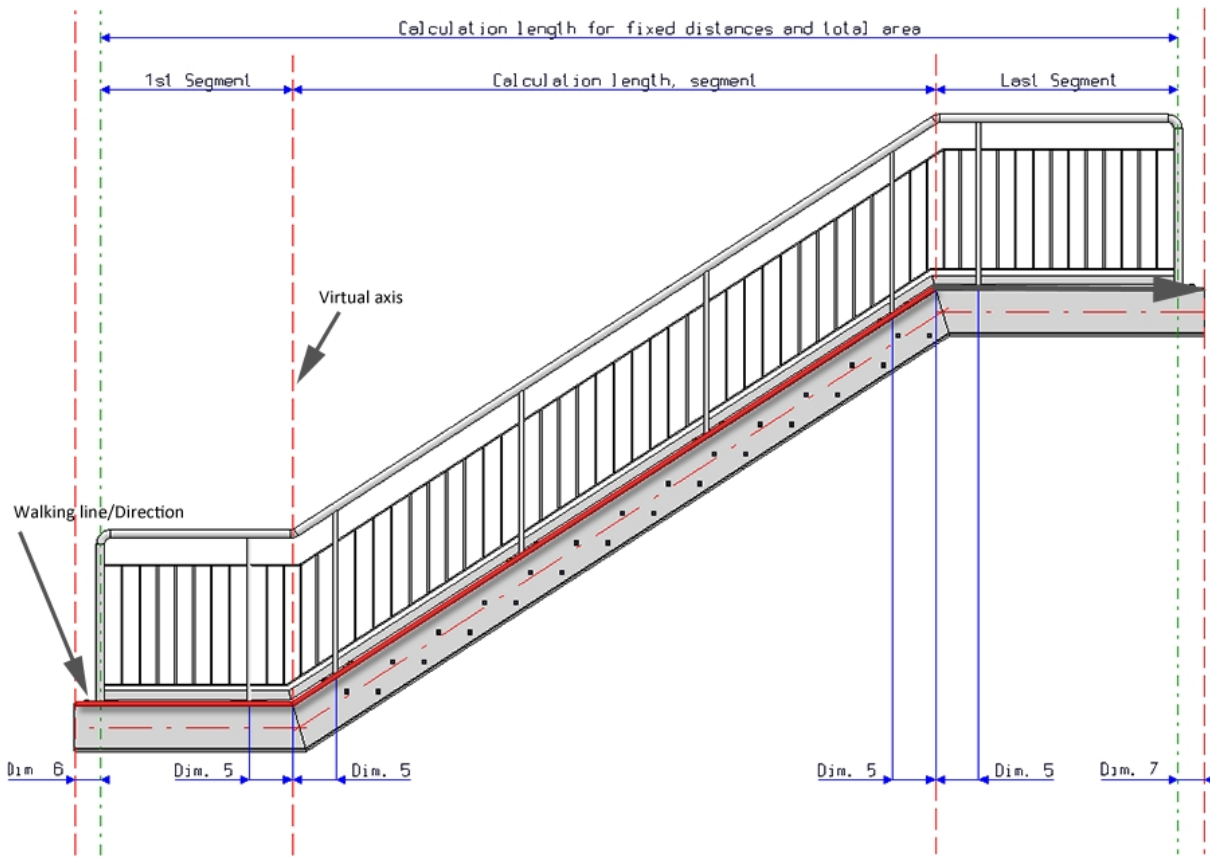

Example: Distribution of posts across complete walking distance (different at transitions)

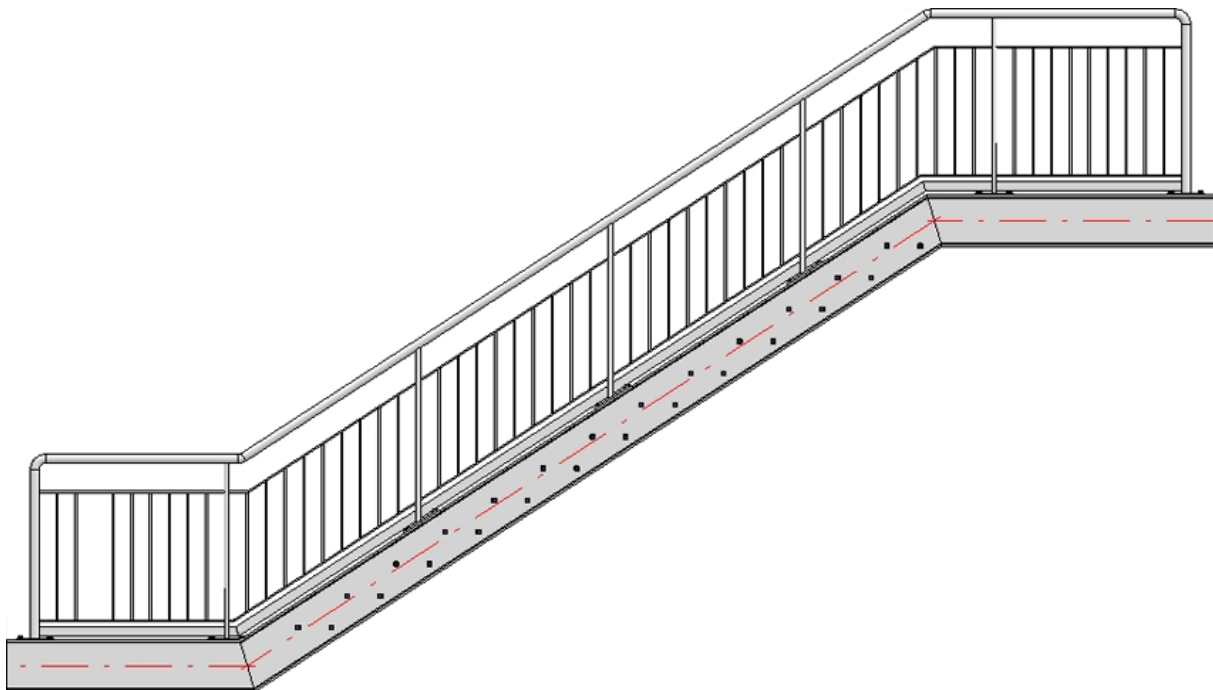

Reference for distances

The distance can either be interpreted as

- distance between the post axes, or
- as a so-called "clear width" i.e. the inner distance between the posts

Offset

- **Corner distance (4)**
Distance of the post axes to the corner points of the walking line.
This dimension is only applies if the posts are distributed by segments, and if the **Create corner posts** beneath **Create which posts?** has been deactivated.
- **Transition distance (5)**
The distance of the first post to the beam start
This dimension is only applies if the posts are distributed by segments, and if the **Create transition posts** beneath **Create which posts?** has been deactivated. Please note that the mid point of this dimension is always located on a corner point of the walking line.
- **Start distance (6)**
Distance of the first post to the start of the first beam
- **End distance (7)**
Distance of the last post to the end of the last beam

If the start point and the end point are not equal, please check which beam you selected first. The start distance always refers to the first selected beam, the end distance to the last selected beam!

The start and end distance, that is, the position of the first and the last post, can also be specified via point determination. To do this, click the  icon and specify the position of the post.

Create which posts ?

Here you specify by activating the corresponding checkboxes which posts are to be created. The creation of corner and transition posts is only possible if the **By segments** option beneath **Reference for post distribution** is active and if the guideline has a corner or a transition.



Example, Step 2 - Specify parameters on Walking line (1) and Post distribution (2) tabs

In our example the ISD default settings (with max. post distances, distribution of posts by segments) will be used, with the exception of the Offset value on the Walking line tab. The railing is to be placed in a centred position on the upper beam side. Therefore, select Offset = 0 here.

Individual post distribution

The post distribution can also take place manually, i.e. with different distances between the individual posts. For this



you can use the **Auto** option.

When you click the button, the settings that were last specified on the **Post distribution** tab of the dialogue window will be displayed as defaults for individual post distribution. This includes the definition of the distances at the start and the end of the walking line, the corner distance and the transition distance with concrete values. Therefore, the **Individual** option is initially greyed out. The settings can then be modified as described below.



After a click on the button the **Individual** option will be available. You can then (while the dialogue is open) switch between the other options beneath **Distribution of posts** and the individual distribution.

The screenshot displays the 'Railing Configurator' software interface. On the left, the 'Distribution of posts' and 'Reference for post distribution' tabs are active. The 'Distribution of posts' section has 'Evenly, with number of posts' selected. The 'Reference for post distribution' section has 'By segments' selected. Below these, there are checkboxes for 'Create start post', 'Create end posts', 'Create corner posts', and 'Create transition posts'. The 'Reference for distances' section has 'Post axis - Post axis' selected. The 'Offset' section shows values for corner, transition, start, and end distances. A red arrow points from the 'Auto->Individual' button to the right-hand side of the interface.

On the right, the 'Individual post distribution' dialog is open, showing two segments. Segment 1 has 6 posts with distances of 150, 867, 867, 867, 867, and 500. Segment 2 has 6 posts with distances of 500, 479, 479, 479, 479, and 150. Each distance has an 'Auto' checkbox next to it.

Left: Last settings; Right: Individual post distribution after clicking



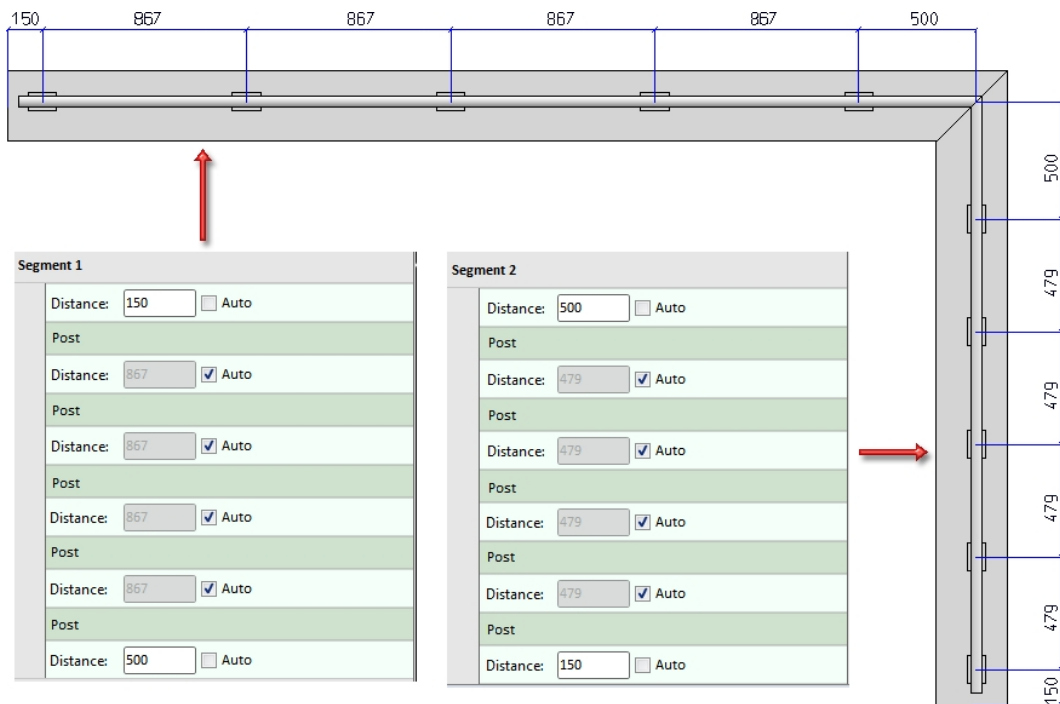

If you activate the **Auto** checkbox, all distances will be recalculated. If you want to define individual distances, deactivate the corresponding **Auto** checkbox and enter the required distance. All distances with an active checkbox will continue to be calculated automatically.

When you move the cursor over the entries for the posts, the corresponding post will be highlighted in green in the drawing. Distances between posts are highlighted in red, all other distances in blue.

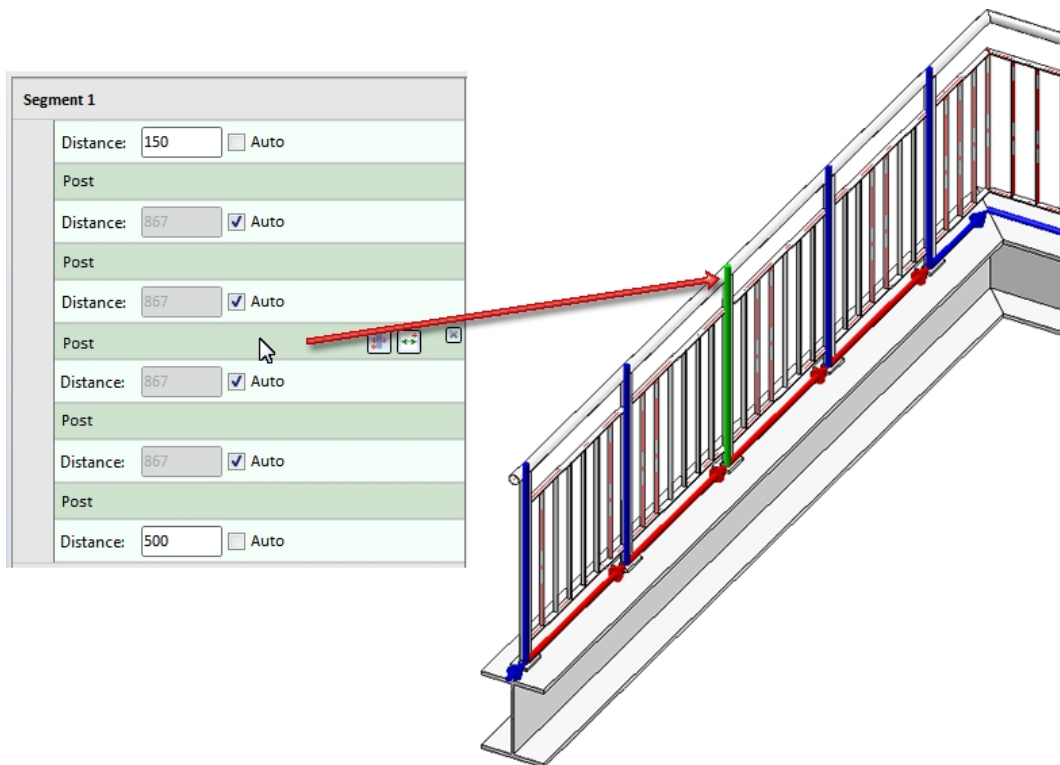

In the post distribution list you can also add new posts and distances with the help of functions the icons of which become visible when you move the cursor over the **Segment**, **Distance** and **Post** rows.

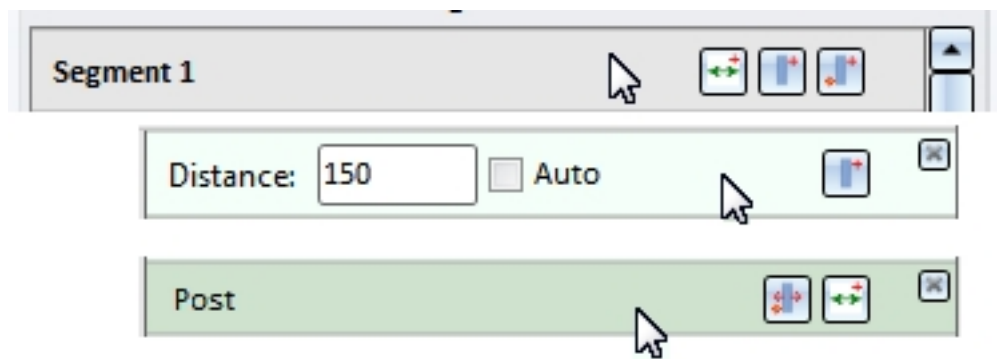

The meaning of the symbols:

Segment



New distance at start of segment

Adds a new auto-distance at the start of the segment. All other distances with active **Auto** checkbox will be recalculated.



New post at start of segment

Adds a new post at the start of the segment.



New post, via point

Allows the insertion of a new post at a defined point.

Distance



New post

Adds a new post after the current distance.



Delete distance

Post



Move post, via point

Moves the current post to a defined point. Specify the point on the segment.



New distance

Inserts a new auto-distance after the current post. All other distances with active **Auto** checkbox will be recalculated.



Delete post

The Distance and Post rows can be moved by Drag & Drop.

If the post distribution cannot be applied with the specified data, e.g.

- because no distance between 2 posts has been defined, or
- because a post would be located outside the segment due to the entered data,

this will be indicated accordingly on the **OK** and **Preview** buttons by the symbol, and in the post distribution section by the symbol. If you move the cursor over the symbols, a short explanation of the error will be displayed, e.g.:

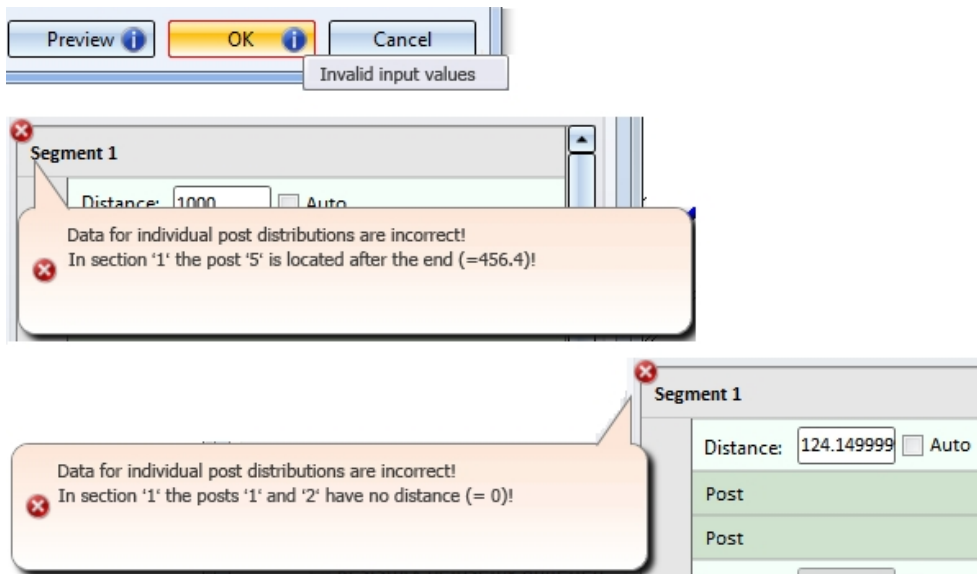

3) Post

One distinguishes between Start posts, Intermediate posts, Corner/Transition posts and End posts.

Value inputs for posts

Railing Configurator

Post - Sub-structure Post - Handrail Handrail - Handrail Skirting board - Skirting board

1) Walking line 2) Post distribution 3) Post 4) Handrail 5) Infill 6) Skirting board

All posts equal

Lateral offset to handrail: 0

- Start post

Variant: Post from standard beam

Post: Rohr EN 10220 48.3x2.6 - S235JRH

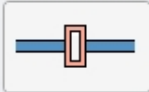
Beam orientation 

- Intermediate post(s)

Variant: Post from standard beam

Post: Rohr EN 10220 48.3x2.6 - S235JRH

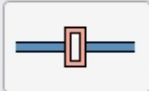
Beam orientation 

- Corner post/Transition post

Variant: Post from standard beam

Post: Rohr EN 10220 48.3x2.6 - S235JRH

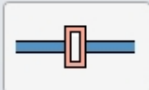
Beam orientation 

- End post

Variant: Post from standard beam

Post: Rohr EN 10220 48.3x2.6 - S235JRH

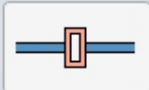
Beam orientation 



Profiles from the catalogues listed below can be used as posts. Sheets, double profiles or sketch profiles can also be used as posts.

Post from standard beam	<p>All profiles from the catalogues</p> <ul style="list-style-type: none"> ■ Semi-finished products > Beams+Profiles > Flat steel ■ Semi-finished products > Beams+Profiles > Hollow profiles ■ Semi-finished products > Beams+Profiles > Steel pipes ■ Semi-finished products > Beams+Profiles > Round steel
Variant: Steel plate post	<p>All plates from the catalogues</p> <ul style="list-style-type: none"> ■ Semi-finished products > Plates > Plate
Variant: Post of double profiles	<ul style="list-style-type: none"> ■ Factory standards > Railing > Railing profiles > ISD Examples - Double profiles
Variant: Sketch profile	<ul style="list-style-type: none"> ■ Factory standards > Railing > Railing profiles

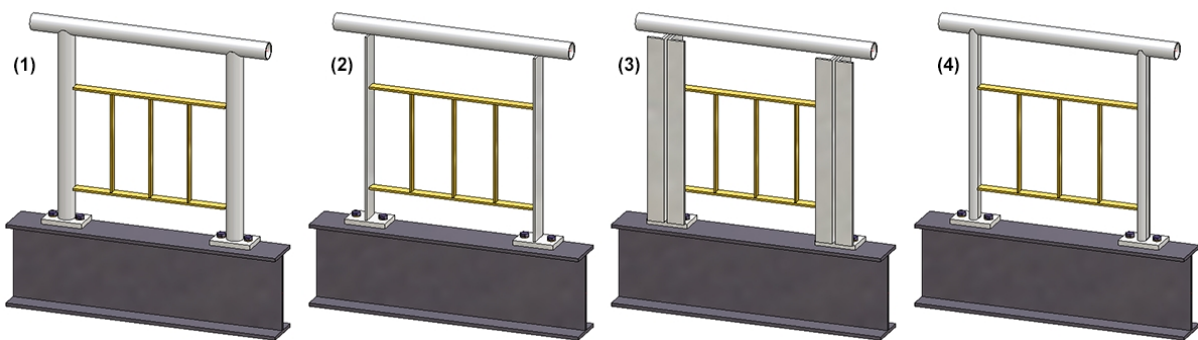

(1) Standard profiles, (2) Plate, (3) Double profiles, (4) Sketch profiles

For all posts you can specify a lateral offset to the handrail. By activating or deactivating the corresponding checkbox, you can also change the **Beam orientation**.

Please note that specifying an offset currently only makes sense if **Variant: Console** has been selected on the **Post-Handrail** tab.

If you want the beam height to be perpendicular the the railing plane, activate the **Beam orientation** checkbox.

Please note:
Even if you activate the **All posts equal** checkbox here, the settings on the tabs **Post - Substructure** and **Post - Handrail** will not be considered for corner posts and transition posts! The connections on corner posts and transition posts must therefore be reworked manually.

Offset - Example:

The image below shows the marked handrail and post in top view: (1) without offset; (2) with offset

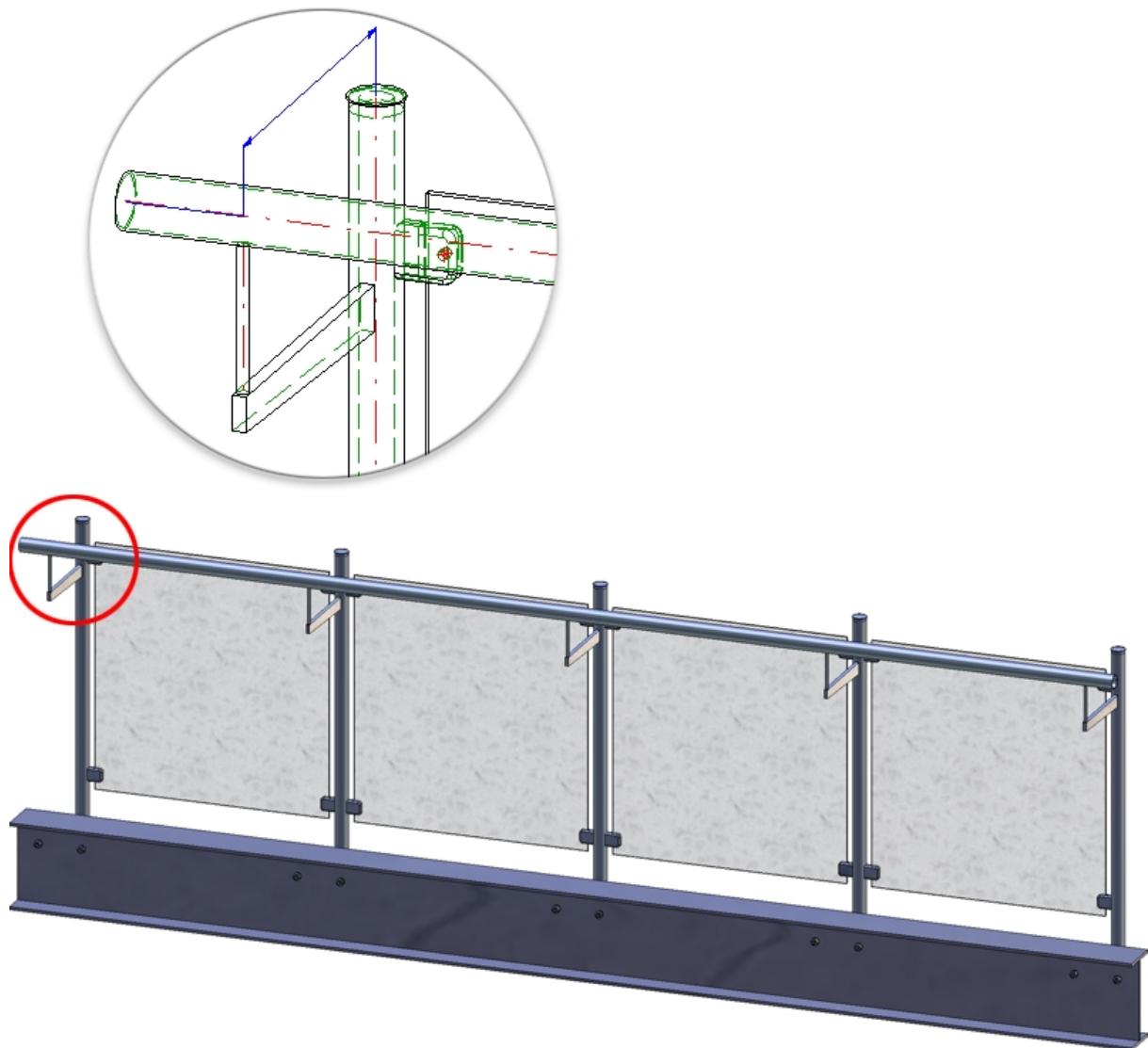

Please note:

Value inputs in the Corner post/Transition post area will only be possible if the **By segments** option has been selected beneath **Reference for post distribution** on the **Post distribution** tab, and if the guideline has corners or transitions.

4) Handrail

The variant supplied by the ISD allows an utilization of steel pipes as handrails. In addition, you can specify an excess length for the handrail at the start post and the end post. However, the excess length will only be evaluated if you have selected the variant **<do not create>**, **Trim pipes** or **Connection with mandrel** on the **Post - Handrail** tab.

Value inputs for handrail

- Handrail

Variant: Handrail from standard profile

Excess length on first post: 100

Excess length on second post: 100

Handrail: Pipe EN 10220 48.3x2.6 - S235JRH

Beam orientation

Handrail terminations equal

- Handrail termination, Start

Variant: Elbow (own production)

- Form

Elbow: DIN 2605-1-90-2-42,4x

Orientation: Wall

Invert:

- End

Type: Steel plate

Options: BI 5 - S235JR

Layer for auxiliary points: 0

- Handrail termination, End

Variant: <Do not create>

In addition, you have the option here of specifying the termination at the beginning and end of the handrail. Available are end caps and ball caps as well as elbow with or without end cap or steel plate. Elbows can also be oriented towards walls or floors, or reversed by activating the corresponding checkbox.

If the auxiliary points for the selected standard parts are to be assigned to a special layer, enter the number of the layer here. The default setting is Layer 0.

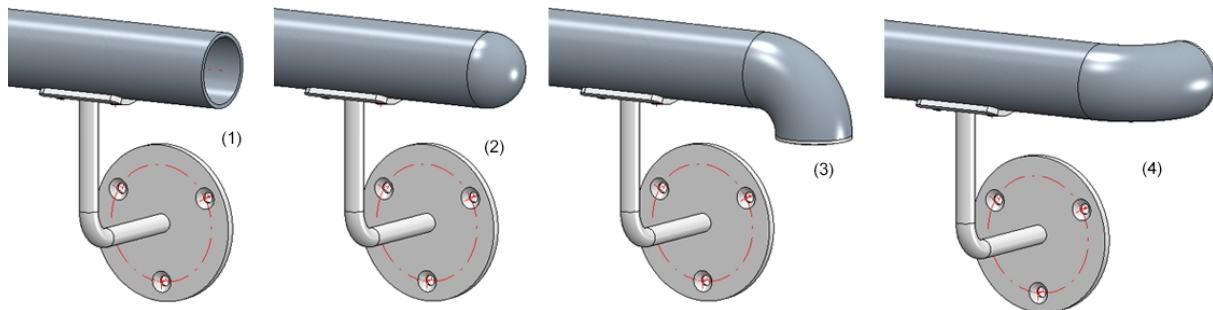

(1) no end element, (2) with ball cap, (3) with elbow and end cap / oriented towards floor, (4) with elbow and end cap / oriented towards wall

5) Infill

Infills can either be created between the posts, or continuously for an entire segment.

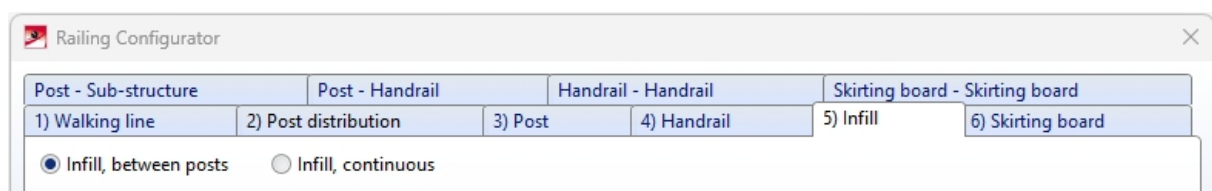

Infill, between posts

You can choose knee rails, glass elements, vertical rods with or without cross-members, vertical rods with bottom cross-members, or vertical rods with frame. The infill for corners and transitions (staircase/platform) can be defined separately. However, this is only possible if the guideline has corners and transitions and if the checkboxes for the creation of corner and transition posts have been deactivated on the **Post distribution** tab.

For corners or transitions, the same infills as specified in the **Infill** tab will be used by default. If you want to use individual infills here, activate the corresponding checkbox. Please note however that this will only be possible if no corner posts or transition posts are used.

Knee rails

Value inputs for knee rails

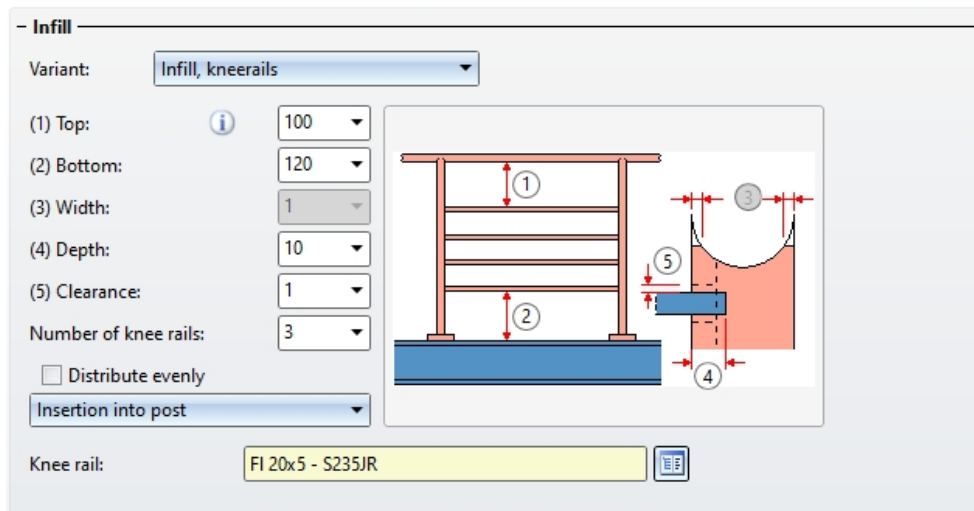

If you want the knee rails to be distributed evenly, activate the **Distribute evenly** checkbox.

For **Knee rails on posts** you can choose between the following options:

- Do not trim (1)
- Trim to post (2)
- Trim to front edge of post (3)
corresponds to the function **Trim, to outer edge**
- Insertion into post
Here the infill is inserted into the post, with a definable depth.

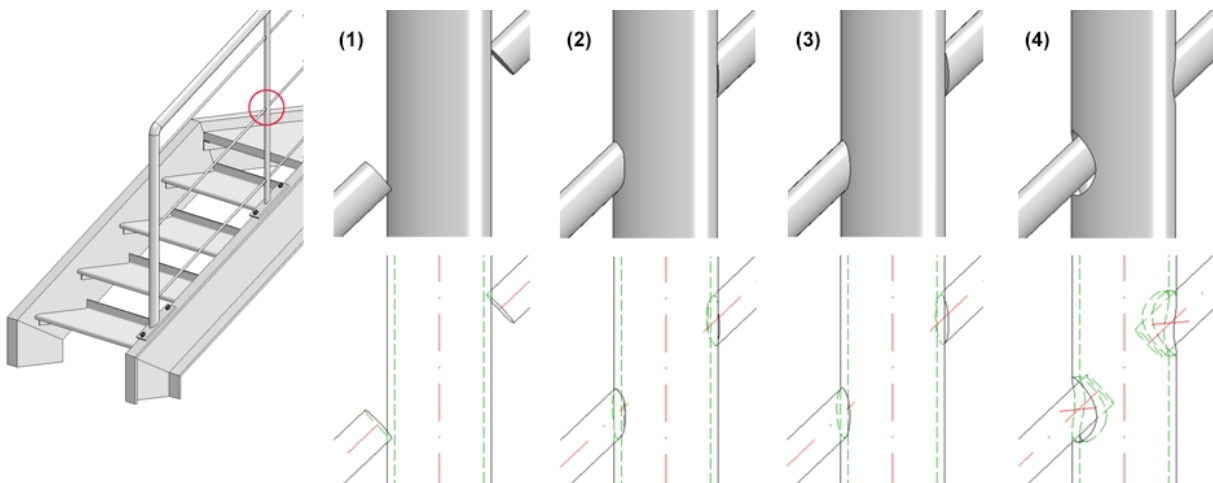

Glass elements

Value inputs for glass elements

- Infill

Variants:

Glass holder

Top 

Bottom 

Values from glass holder catalogue

Pre-mounted

Glass



Bores, top

Bores, bottom

Bore diameter:

Processing of post



Thread Blind rivet

Offset

(1) Lateral:

(2) Top:

(3) Bottom:

(4) Distance:

(5) Distance:

(6) Distance:

(7) Clearance:

Allowed glass elements (Material and glass structure) are the glass panes from the catalogue **Factory standards > Glass panes**, allowed glass holders can be found in the catalogue **Factory standards > Purchased/Factory standard parts**.

If you want to insert glass holders, activate the corresponding checkboxes and choose the desired glass holders from the catalogue. If the **Values from glass holder catalogue** checkbox has been activated, the values for the

- Lateral clear distance to post,
- Clear distance between the post and the bore centre of the glass holder, and
- the bore diameter

stored in the catalogue will be used. In this case the input fields **(1) Lateral**, **(6) Distance** and **Bore diameter** will be locked. Enter the values for the

- Clear distance to the lower edge of the handrail,
- Clear distance to the finished floor,
- Distance of the bore to the upper edge of the glass,
- Distance of the bore to the lower edge of the glass, and
- the clearance.

If the **Values from glass holder catalogue** checkbox has been deactivated, all input fields (with the exception of Clearance) will be available.

You use the **Pre-mounted** checkbox to determine to which assembly the glass holders are to be assigned. If the checkbox has been activated, the glass holders of the assembly will be assigned to the assembly of the relevant post; otherwise, they will be assigned to the assembly of the infill.

The glass element can be inserted with or without bores, by activating or deactivating the relevant checkboxes.

If you do not want the glass holders to be welded on, you can choose a different type of fixing (Thread or Blind rivet) in the **Processing of post** section.

Settings for individual corner infill

Individual corner infill

Variants:

Glass holder

Top 

Bottom 

Values from glass holder catalogue

Pre-mounted

Glass



Bores, top

Bores, bottom

Bore diameter:

Processing of post



Thread Blind rivet

Offset

(1) Lateral:

(2) Top:

(3) Bottom:

(4) Distance:

(5) Distance:

(6) Distance:

(7) Clearance:

Glass holder, top 

Glass holder, bottom 

Values from glass holder catalogue

Bores, top

Bores, bottom

Bore diameter:

(8) Bore distance:

(9) Bore distance:

(10) Distance:

(11) Distance:

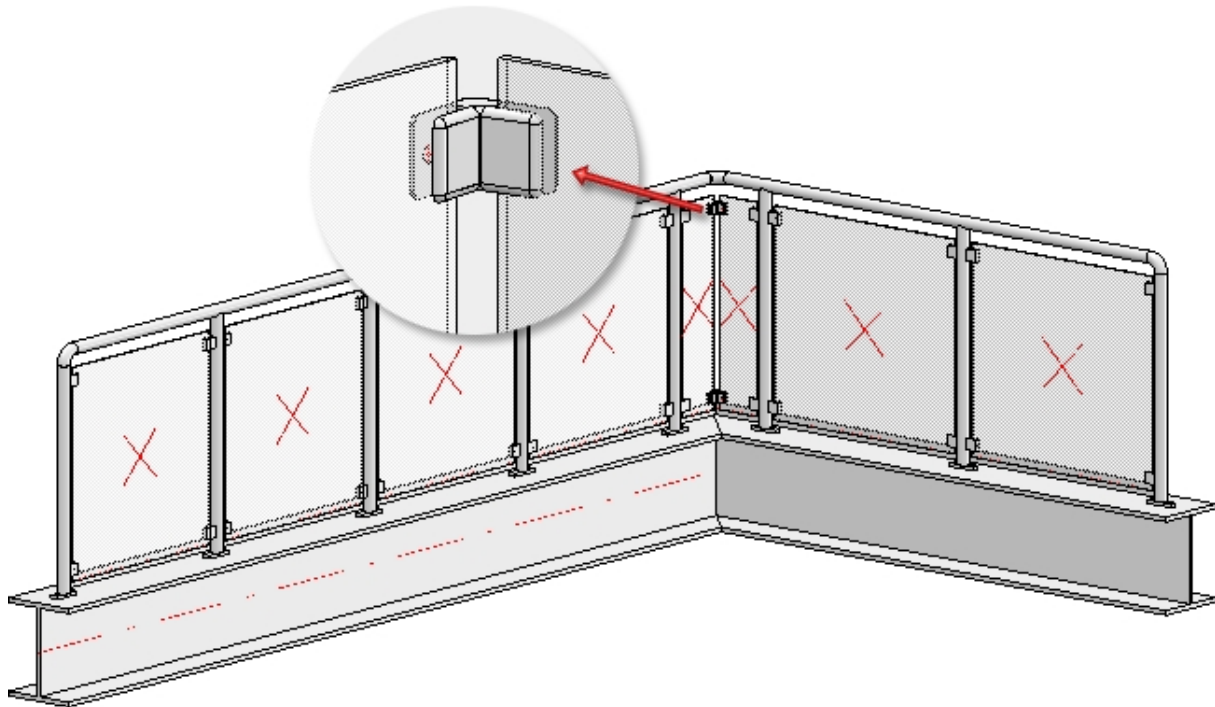

Example of a glass railing with individual corner infill



No usage is assigned to glass panes. This enables you to use the DEFAULT(GLASSSCHEIBEN) configuration for the workshop drawing.

Vertical rods

Here you can define vertical rods which can be rotated, in addition to the knee rails. Depending on the type of the chosen variant the connections will be with the beam, with the handrail, the post or the cross-member. For example: the vertical rods can be inserted in the handrails or can be trimmed at the handrails, with or without contour. Furthermore, you can specify whether the cross-members on the posts and the filling rods on the cross-members are to be trimmed.

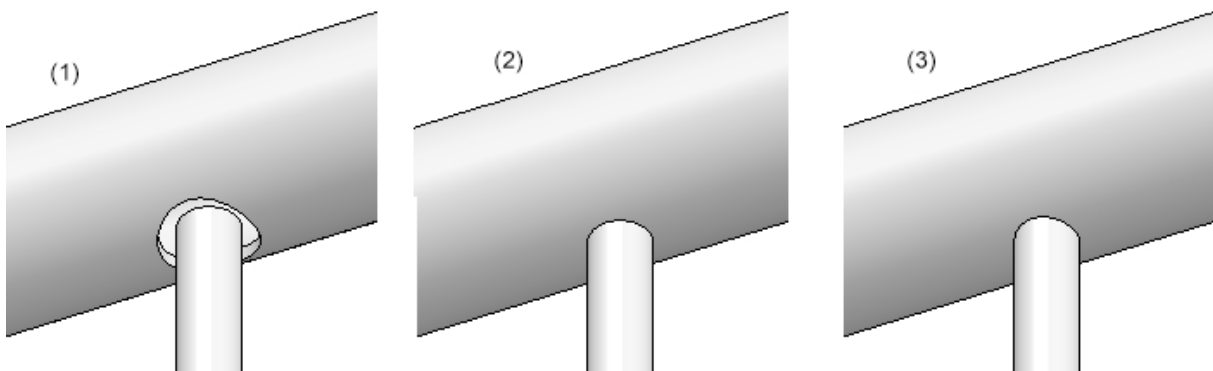

(1) Inserted in the handrails with gap, (2) without trim, (3) trim with contour

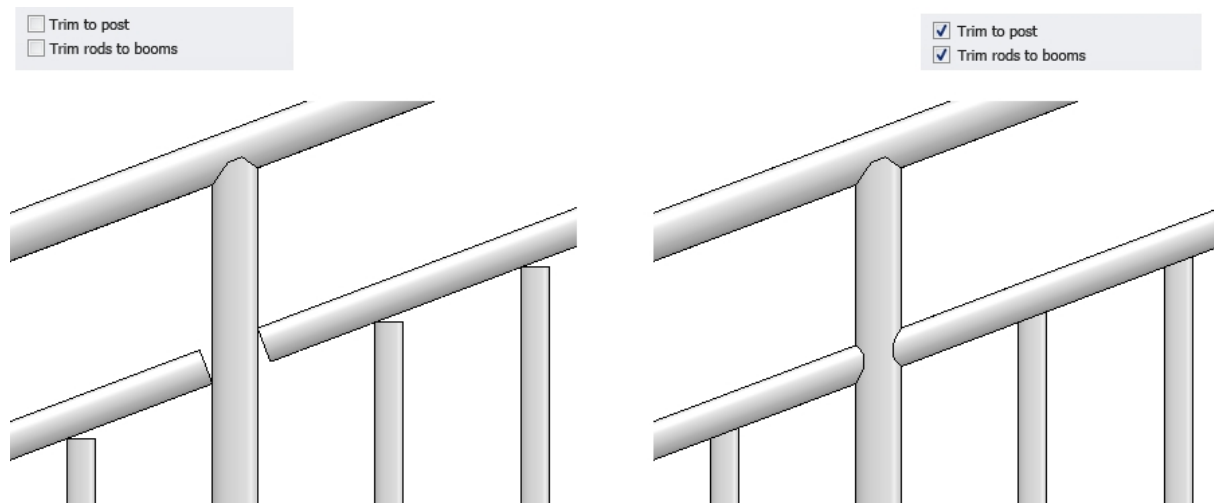

Vertical rods with cross-members - untrimmed (left) and trimmed (right)

Value inputs for vertical rods without cross-members

- Infill

Variant: Vertical rods without cross-member

- Rods

Rods: FI 20x5 - S235JR ☰

(1) Distance: 120

Rod rotation angle: 0

Connection, Handrail: Trim, without contour

Connection, Beam: Do not trim

- Infill, corner

Corner infills can only be defined if:

1. the guideline has corners
2. no corner posts are created (see 'Post distribution')

- Infill, transition

Transition infills can only be defined if:

1. the guideline has transitions
2. no transition posts are created (see 'Post distribution')

For vertical rods with cross-members, bottom cross-member or frame, you select the cross-members, the bottom cross-member or frame, complete with rods and spacers from the catalogue.

For round to round connections you can also specify the parameter **Width**, referring to the width of the obtuse end.

Value inputs for vertical rods with cross-members

- Infill

Variant: Vertical rods with cross-members

(1) Top: 150

(2) Bottom: 100

(1)+(2): Perpendicular to handrail

(3) Distance: 120

(4) Width: 1

Rod rotation angle: 0

Trim to post

Trim rods to cross-members

Cross-members: FI 30x6 - S235JR

Rods: FI 20x5 - S235JR

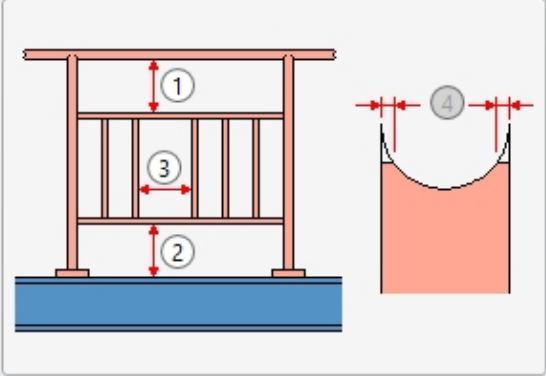

- Infill, corner

Corner infills can only be defined if:

1. the guideline has corners
2. no corner posts are created (see 'Post distribution')

- Infill, transition

Transition infills can only be defined if:

1. the guideline has transitions
2. no transition posts are created (see 'Post distribution')

Value inputs for vertical rods with bottom cross-member

- Infill

Variant:

- Rods

Rods: FI 20x5 - S235JR

(2) Distance:

Rod rotation angle:

Connection, Handrail:

Connection, cross-member:

- Cross-members

Cross-members:

(1) Bottom: Perpendicular to handrail

Connection, Post:

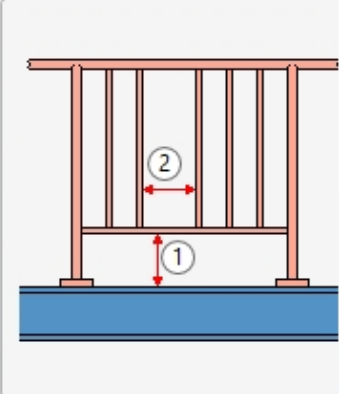

- Infill, corner

Corner infills can only be defined if:

1. the guideline has corners
2. no corner posts are created (see 'Post distribution')

- Infill, transition

Transition infills can only be defined if:

1. the guideline has transitions
2. no transition posts are created (see 'Post distribution')

If the **Perpendicular to handrail** checkbox is active, the distance at the top/bottom is interpreted as a vertical distance between the handrail and the cross-member, or cross-member and beam. This only has an effect on sloping handrails. The following illustration shows the difference:

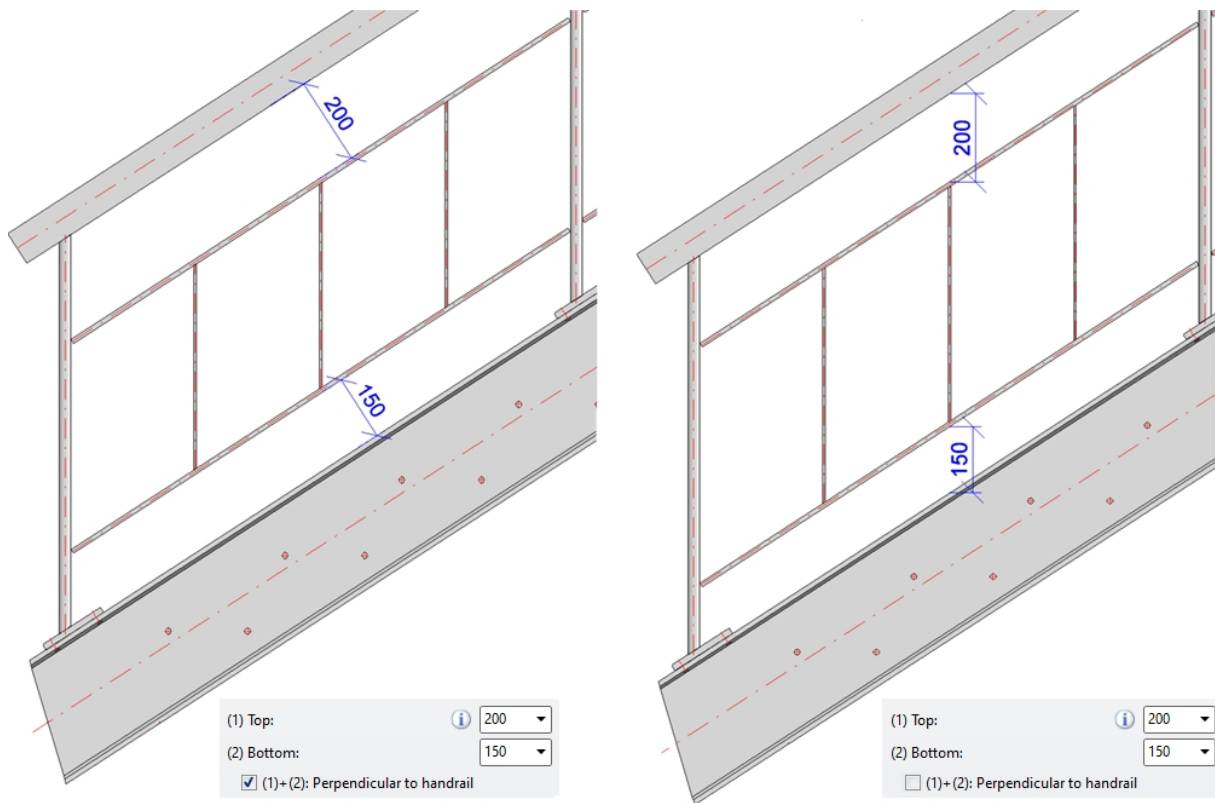

The filling rods can be trimmed to the cross-member and handrail or inserted into them.

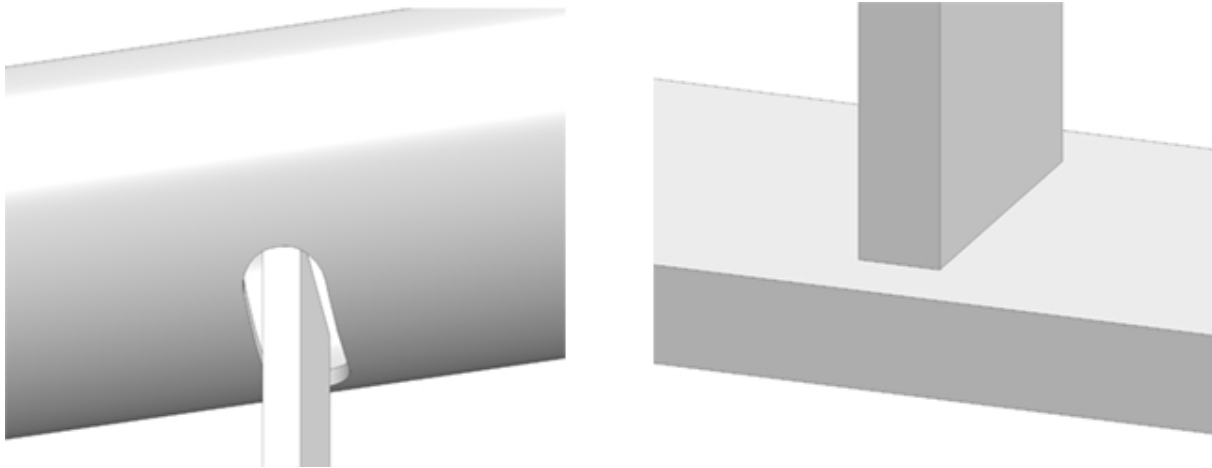

Left: Inserted into handrail, Right: Trimmed to cross-member

Value inputs for vertical rods with frame

- Infill

Variant: **Vertical rods with frame**

(1) Lateral: 50

(2) Top: 70

(3) Bottom: 100

(4) Distance: 120

(5) Distance: 75

Rod rotation angle: 0

Trim rods to cross-members

Trim to post

(6) Width: 1

Frame: FI 30x6 - S235JR

Rods: FI 20x5 - S235JR

Distance piece: VKT 16 - S235JR

By deactivating the **Rods** checkbox you can also create railings that have only frames, but no rods.

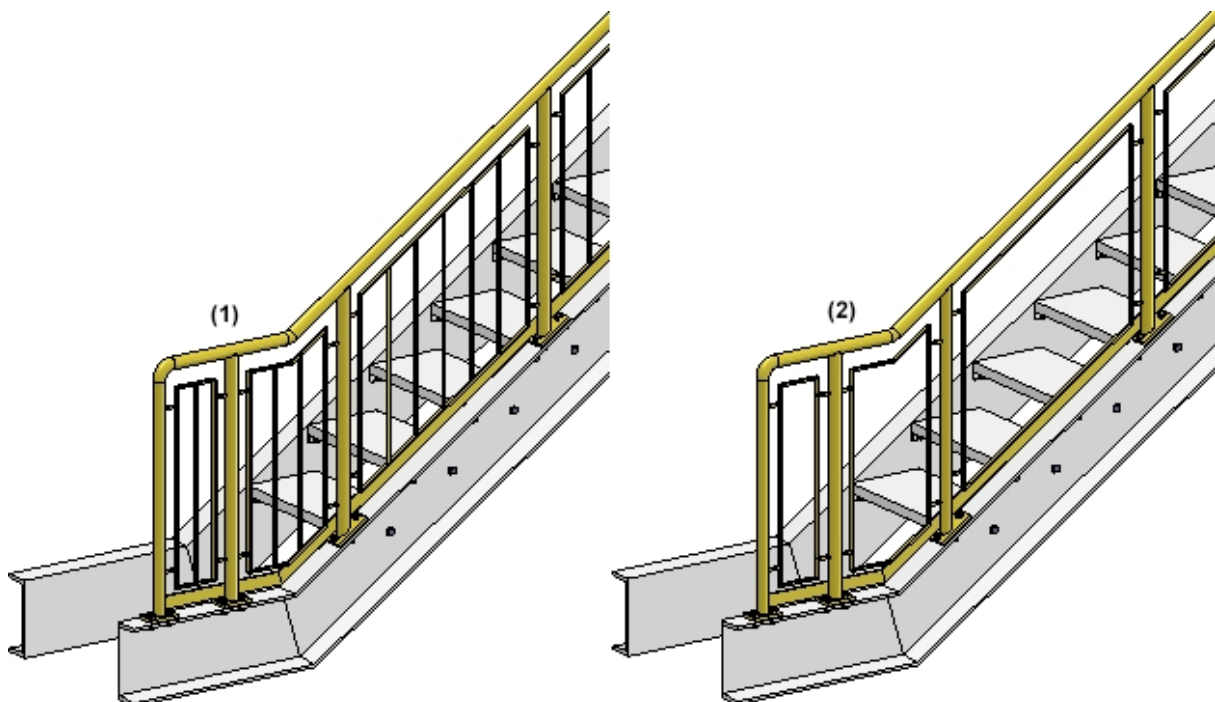

(1) Frame with rods; (2) Only frame

If you want to place rods in corners of beam frameworks, activate the **Corner rod** checkbox. For transition infills, use the **Individual transition infill** checkbox. If this checkbox has been activated, one rod will always be placed exactly into the corner or in the transition area. If the corner rod should be aligned to the angle bisector, please activate the **Align angle bisector** checkbox.

Please note that corner or transition rods can only be placed if no corner or transition posts have been set.

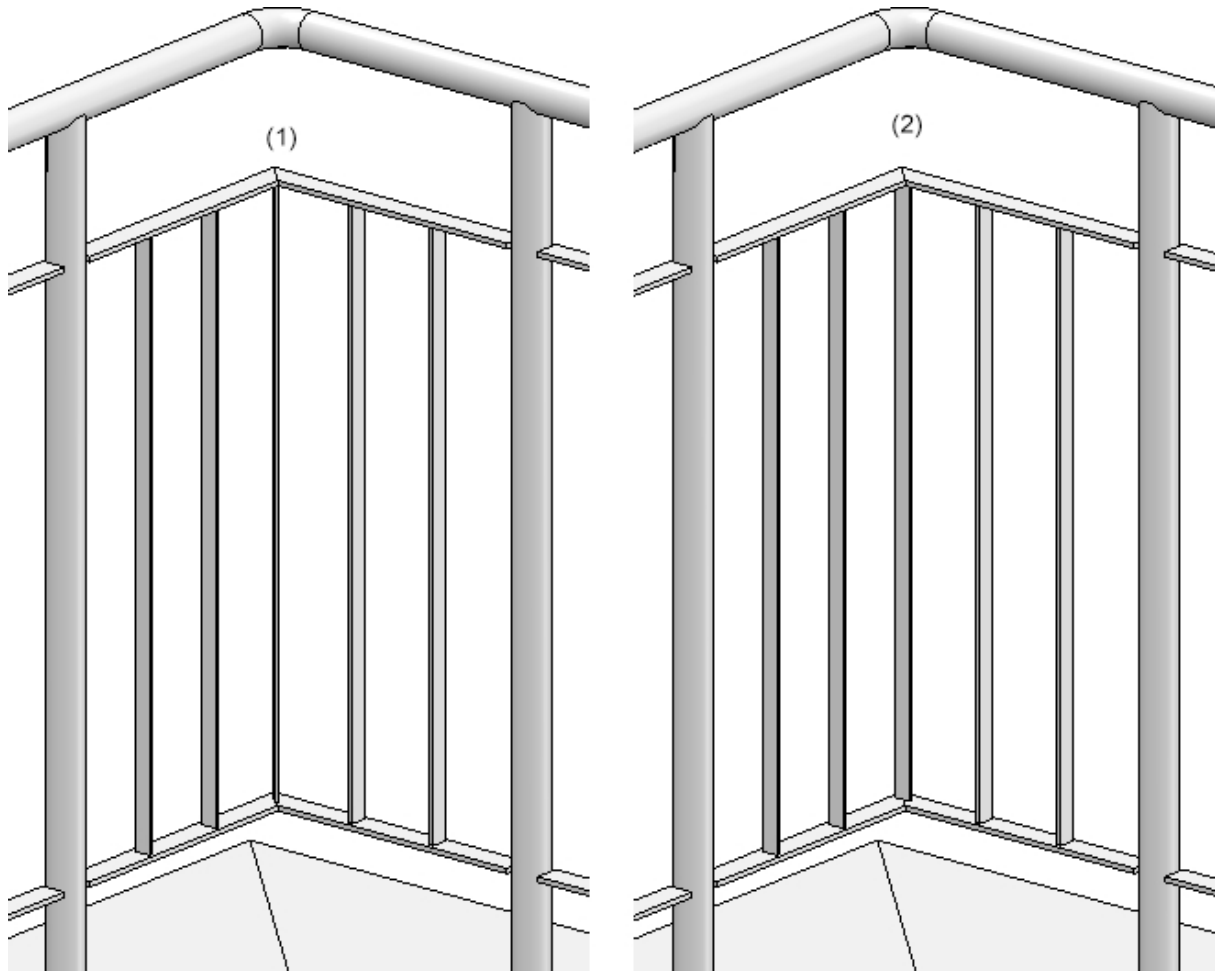

Example of a corner infill: (1) corner rod, bisecting alignment, (2) corner rod, no bisecting alignment

Infill, continuous

With this option, infills can be configured for an entire segment independently of the posts. There is then one infill per segment. The components of the infill are summarised in an assembly called **Continuous infill**.

Two variants are available for continuous infills:

Segment infill through posts

Here, the knee rails run through the posts. The knee rails can be evenly distributed or have a certain distance to the handrail and finished floor.

Infill, between posts Infill, continuous

- Infill, continuous

Variant: Segment infill through posts

Knee rail EN 10060- 16 - S235JR 

Rotate 90°

Number of knee rails: 3

Excess length on first post (1): 100

Excess length at last post (2): 100

Insertion depth in post: 10

Distribute evenly

Clear distance to lower edge of handrail (3): 100

Clear distance to finished floor (4): 100

Clearance for hole in post (5): 0

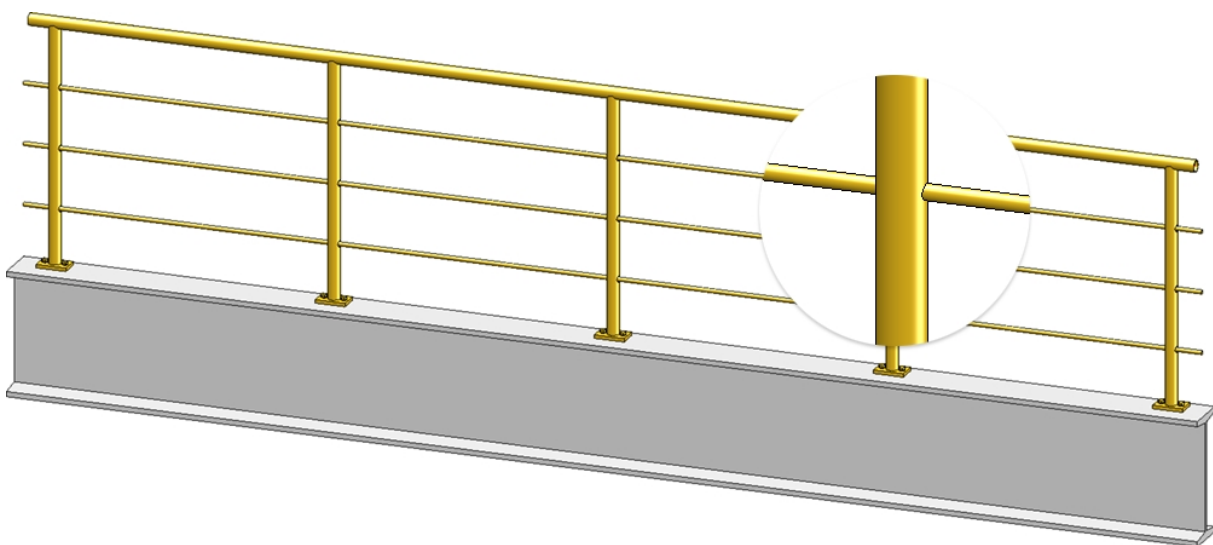
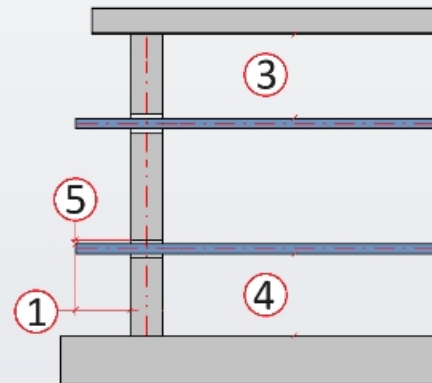







Segment infill with spacers

In this variant, spacers are placed on the posts. The knee rails then pass through the spacers. They can be evenly distributed or have a certain distance to the handrail and finished floor.

Infill, between posts Infill, continuous

- Infill, continuous

Variant: Segment infill with spacers

Distance piece	Holder 100x32x18 - E155	
Switch insertion direction	<input type="checkbox"/>	
Knee rail	EN 10060- 16 - S235JR	
Rotate 90°	<input type="checkbox"/>	
Number of knee rails:	3	
Excess length on first post (1):	100	
Excess length at last post (2):	100	
Clear distance to lower edge of handrail (3):	100	
Clear distance to finished floor (4):	100	
Distribute evenly	<input type="checkbox"/>	

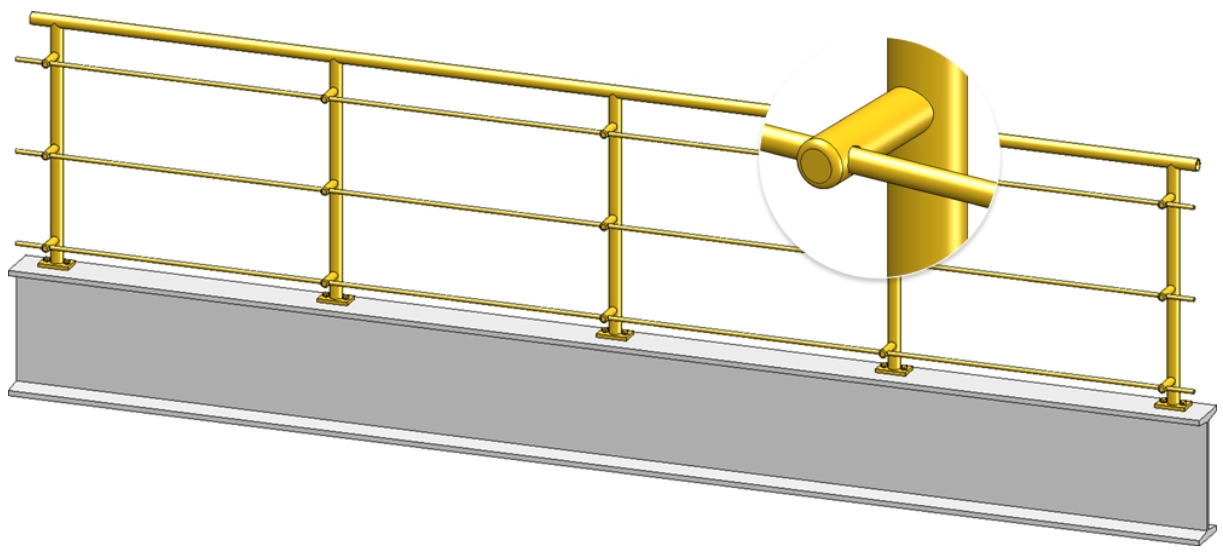
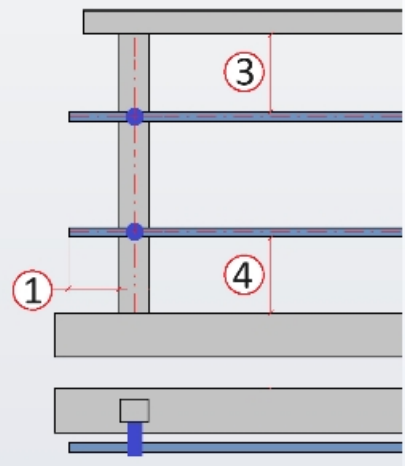

6) Skirting board

Available are skirting boards of flat steel.

Value inputs for skirting boards

Variant:

- Assembling

Skirting boards, All
 Skirting boards, Platforms

Skirting board: 

(1) Gap at bottom:

(2) Distance to post:

- Fixing of skirting board

Internal
 Middle
 External

Trim skirting boards to post

Width of obtuse end: 

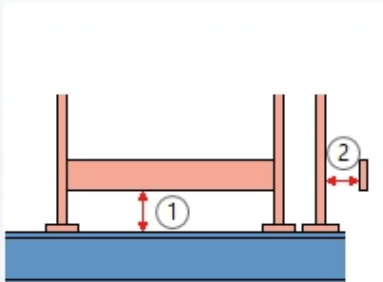

The diagram illustrates the skirting board assembly. It shows a blue base with three vertical posts. A horizontal orange skirting board is mounted on top of the posts. A red double-headed arrow labeled '1' indicates the gap between the bottom of the skirting board and the base. Another red double-headed arrow labeled '2' indicates the distance from the right edge of the skirting board to the rightmost post.

Beneath **Assembling** you can specify by activating the corresponding option whether the skirting boards are to be used everywhere, or only on platforms, i.e. only in the horizontal area, with oblique trimmings (see image below).

Skirting board on platform

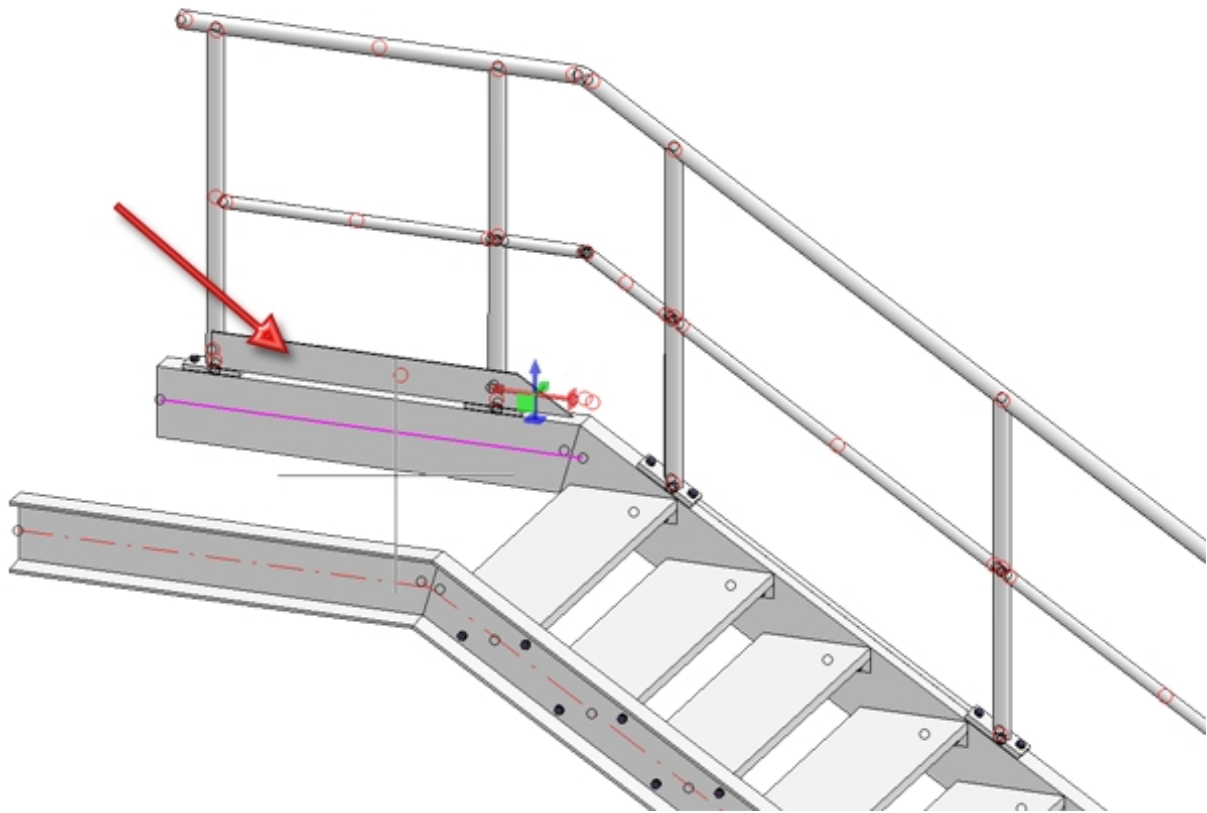

Enter the distance between skirting board and upper beam edge (1) and the distance to the post (2) in the **Gap at bottom** input field.

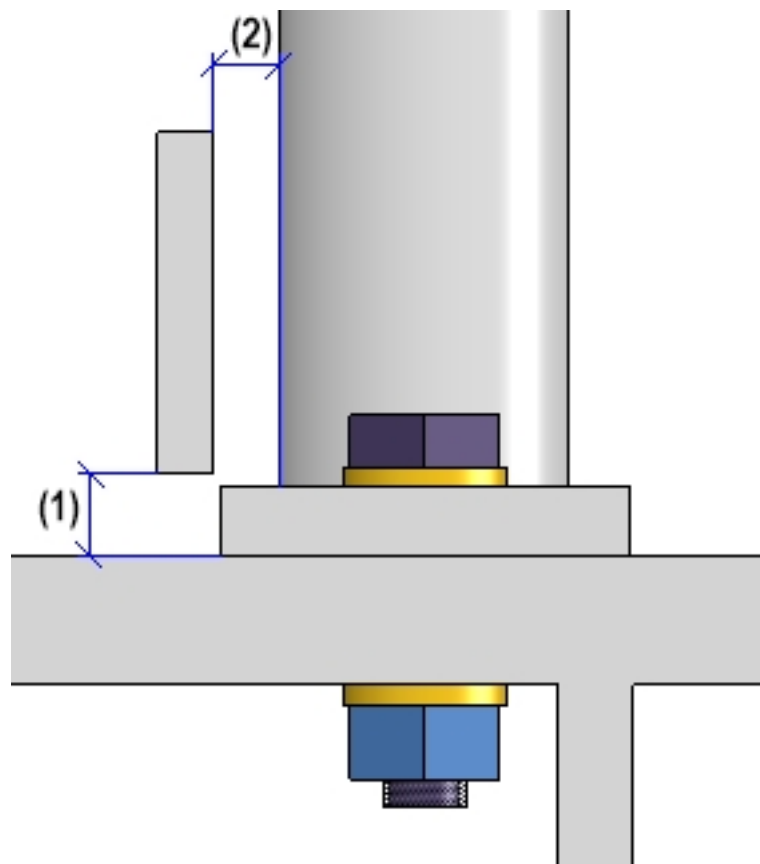

Specify the fixing of the skirting board.

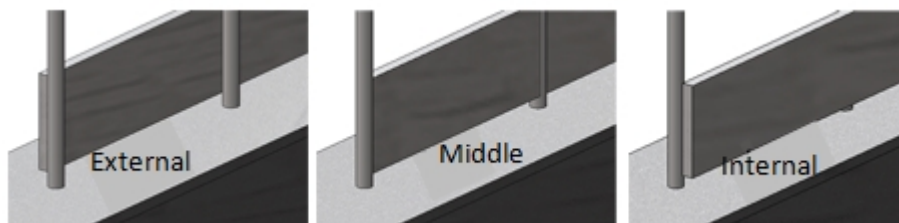



Example - Step 3 - Component selection

In our example we will apply the ISD settings - with one exception - the railing is to be created without skirting boards.

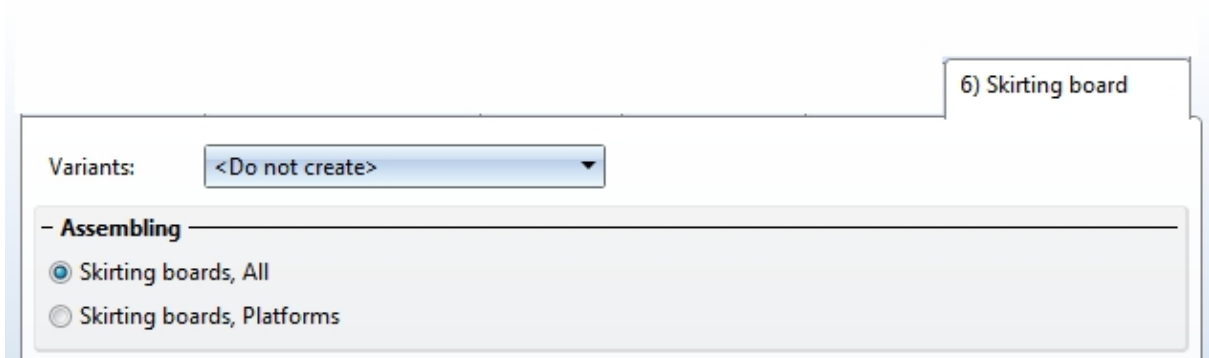

Connecting the railing components

Besides the components, you can create the following connections via the same-named tabs:

- Post - Substructure (1)
- Post - Handrail (2 - 4)
- Handrail - Handrail (5)
- Skirting board - Skirting board (6)

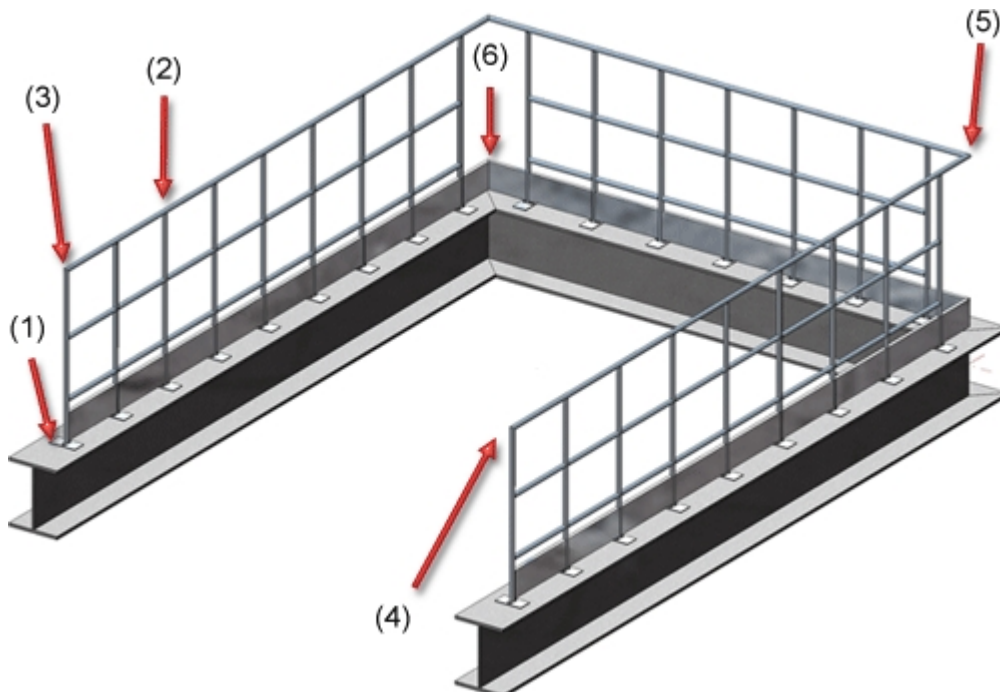

If you do not want to create a connection, select the **<do not create>** option in the corresponding selection box.

Post - Substructure

Here you specify the fixing of the posts to the beams. The posts can be mounted either on the top, side, bottom, or bottom with flat steels to the beam - with or without stiffeners. A bore grid for the base plate can also be selected - possible options are:

- No bores,
- 2 bores or
- 4 bores.

The post connection for the substructure can now be determined separately for

- start, intermediate and end posts and
- corner posts.

Start and end posts can also be determined individually, i.e. independently of the intermediate posts. To do this, you must activate the corresponding checkbox at the top of the dialogue window.

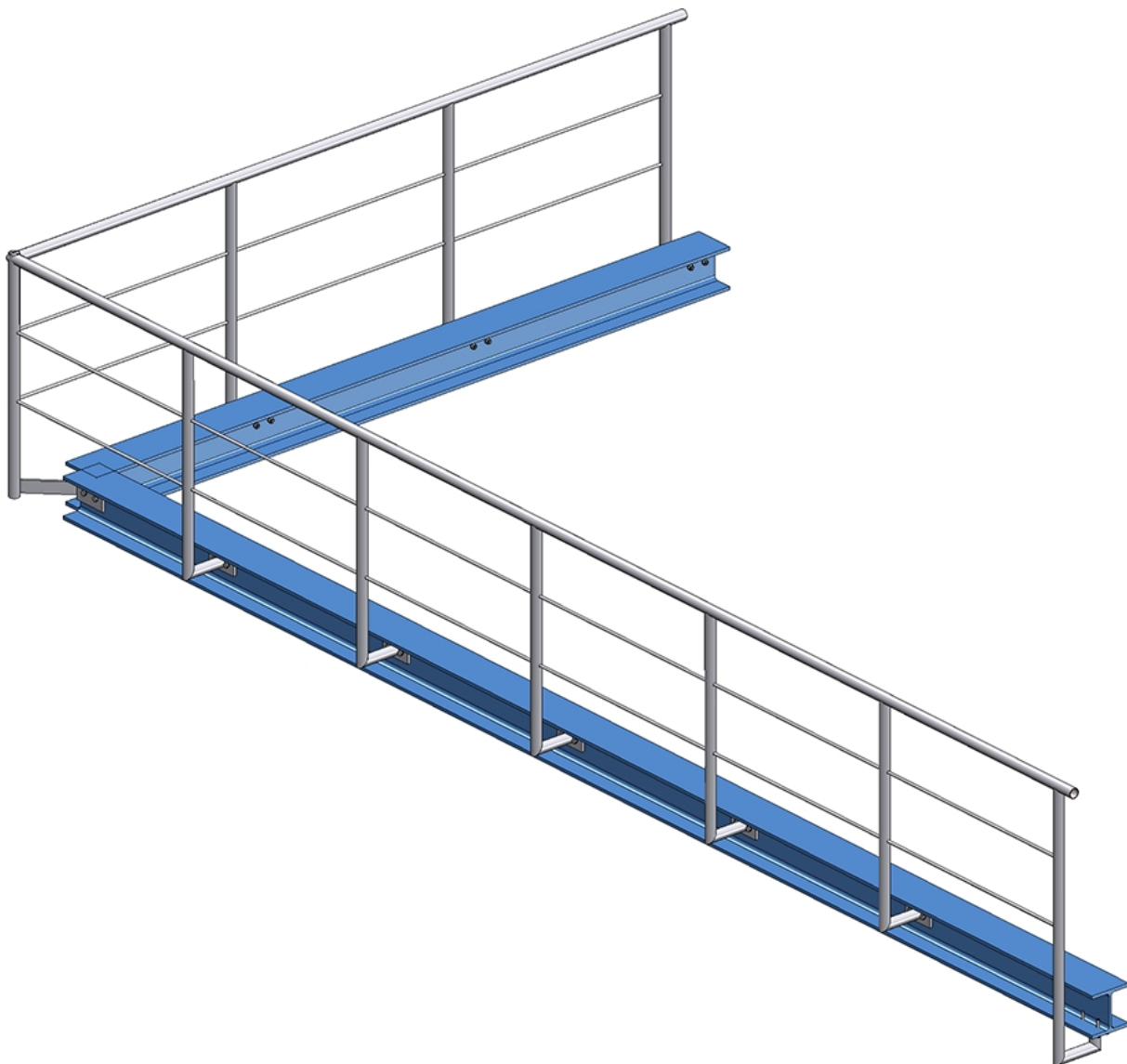

Railing with lateral connection of the start, corner and intermediate posts and connection from bottom for the end post

Please note the following when selecting the post connections: It is only possible to combine the variants **Post connection, lateral** and **Post connection, bottom**. If, for example, you have selected the variant **Post connection, lateral** for a corner or intermediate post and the variant **Post connection, top** for the start or end post, then the installation is not possible and a corresponding error message appears, e.g.

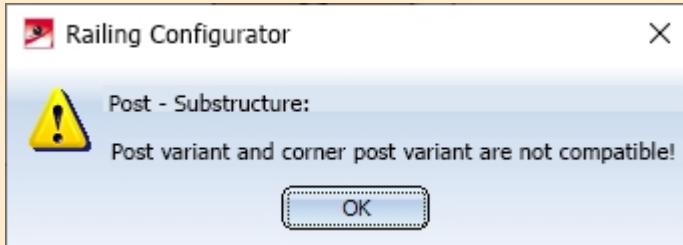

Depending on the selected bore grid, the possible options are:

Bore grid	Input values	
Rect- angular, no bore	<ul style="list-style-type: none"> ■ Half the length of base plate (7) ■ Width of base plate (8) ■ Distances of post (axis) to plate edge (5) and (6) - only for sloping areas ■ Selection of base plate ■ Fillet radius of the corners ■ Selection of stiffeners 	
Rect- angular, 2 bores	<ul style="list-style-type: none"> ■ Distance of bore to plate edge in walking direction (1), ■ Bore distances, i.e. distances of bore centres to post centre (3) and (4) - for sloping areas ■ Distance of post (axis) to centre of bore (2) - for level areas ■ Selection of base plate ■ Selection of bolting ■ Fillet radius of the corners ■ Rotated 90° yes/no ■ Selection of stiffeners 	

Bore grid	Input values	
Rectangular, 4 bores	<ul style="list-style-type: none"> ■ Distance of bore to plate edge in walking direction (1) ■ Distance of bore centre to post axis in walking direction (2) - for level areas ■ Distances of post (axis) to bore centres (3) and (4) - only for sloping areas ■ Distance of plate edge to bore perpendicular to walking direction (9) ■ Distance of bore centre to post axis-perpendicular to walking direction (10) ■ Selection of base plate ■ Selection of bolting ■ Fillet radius of the corners ■ Selection of stiffeners 	

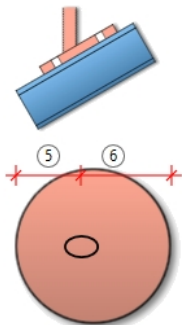
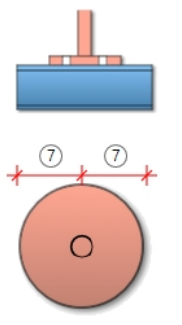
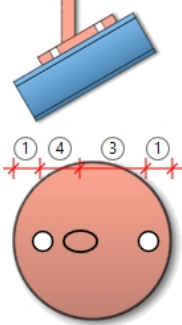
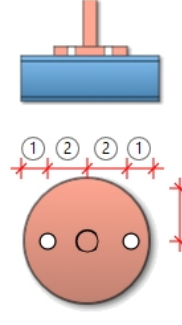
Bore grid	Input values		
Round, no bore	<ul style="list-style-type: none"> ■ Distances of post (axis) to plate edge (5) and (6) - only for sloping areas ■ Radius of the plate (7) - only for level areas ■ Selection of base plate ■ Selection of stiffeners 		
Round, 2 bores	<ul style="list-style-type: none"> ■ Distance of bore to plate edge in walking direction (1), ■ Bore distances, i.e. distances of bore centres to post axis (3) and (4) - for sloping areas ■ Distances of post (axis) to the centre of bore (2) - for level areas ■ Selection of base plate ■ Selection of bolting ■ Selection of stiffeners 		

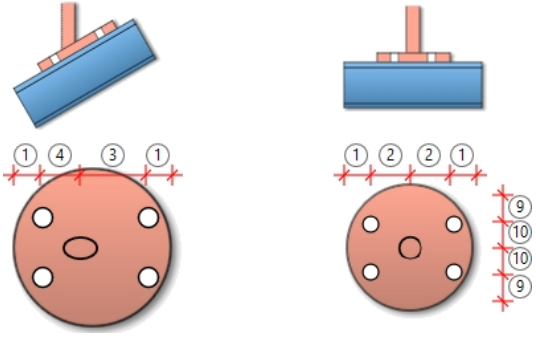
Bore grid	Input values	
<p>Round, 4 bores</p>	<ul style="list-style-type: none"> ■ Distance of bores to plate edge in walking direction (1), ■ Distance of bore centre to post centre in walking direction (2) - for level areas, ■ Distances of post (centre) to bore centres (3) and (4) - only for sloping areas ■ Distance of bore to plate edge perpendicular to walking direction (9) ■ Distance of bore centre to post centre perpendicular to walking direction (10) ■ Selection of base plate ■ Selection of bolting ■ Selection of stiffeners 	 <p>The diagrams illustrate the geometry and dimensions for a round post with four bores. The left diagram shows a sloped plate with dimensions 1, 4, 3, 1. The right diagram shows a horizontal plate with dimensions 1, 2, 2, 1 and 9, 10, 10, 9.</p>

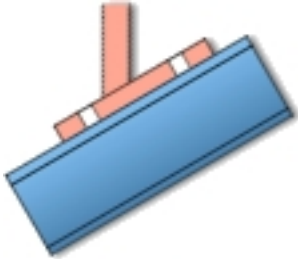
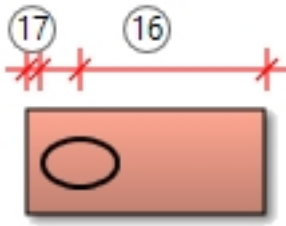
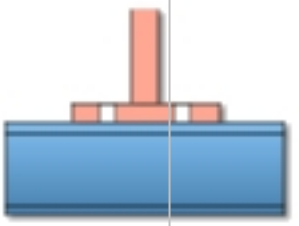
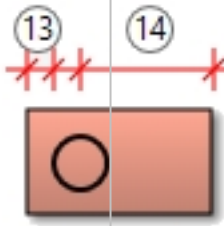
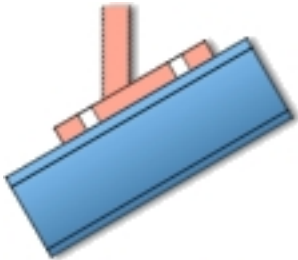
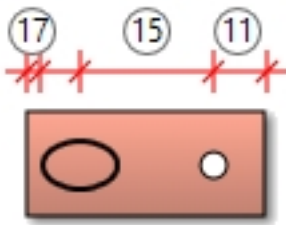
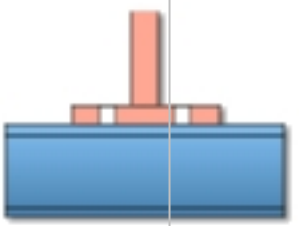
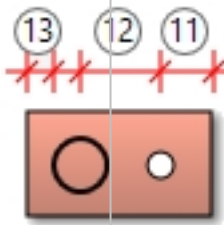
Bore grid	Input values		
One-sided, no bore	<ul style="list-style-type: none"> ▪ Distance of post from plate edge (17), (13) ▪ Distance of post axis to plate edge (16), (14) ▪ Width of base plate (8) ▪ Fillet radius of corners ▪ Selection of base plate ▪ Selection of stiffeners 	 	 
One-sided, 1 bore	<ul style="list-style-type: none"> ▪ Distance of post from plate edge (17), (13) ▪ Distance of post axis to bore centre (15), (12) ▪ Distance of bore (centre) to plate edge (11) ▪ Width of base plate (8) ▪ Fillet radius of corners ▪ Selection of base plate ▪ Selection of stiffeners 	 	 

Bore grid	Input values	
One-sided, 2 bores in transverse direction	<ul style="list-style-type: none"> ▪ Distance of post from plate edge (17), (13) ▪ Distance of post axis to bore centre (15), (12) ▪ Distance of bore (centre) to plate edge (11) ▪ Width of base plate (8) ▪ Distance of bore centre to plate edge (9) ▪ Distance of bore centre to post axis (10) ▪ Fillet radius of corners ▪ Selection of base plate ▪ Selection of stiffeners 	

Optionally, the base plate can be provided with a galvanising hole. To do this, activate the corresponding checkbox and enter the diameter of the hole.

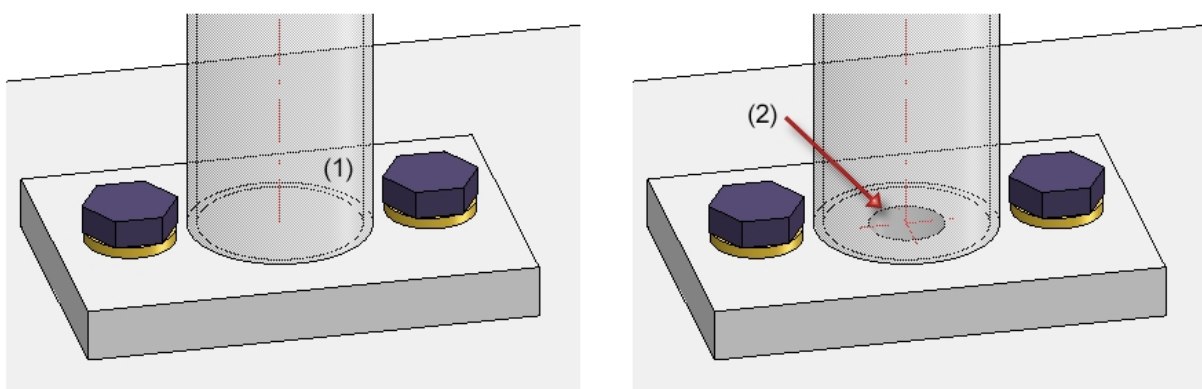

(1) without, (2) with hole for galvanization

Post connection, lateral

Value inputs for Post connection, lateral

- Start, intermediate, end posts

Variant: Post connection, lateral

- Base plate

(8) Distance, plate centre: 150

Base plate: BI 14 - S235JR

Boltings: DIN EN 14399-3-M12-8.8

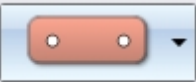
 (3) 40 (2) 0

(4) 75

90° rotated

Fillet radius of corners: 0

- Connection Post-Base plate

Post mitre cut Distance element

Distance element: FI 60x12 - S235JR

End cap, post: End cap-48.3x2.6 (Convex)

(7) Excess length of post: 20

Trim to post 1

Penetration of base plate

- Corner post (on the 'Post distribution' tab, activate 'Create corner posts checkbox')

Variant: <Do not create>

Depending on the selected bore grid, the possible options are:

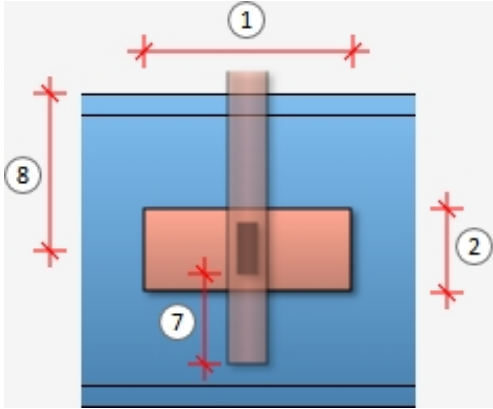
Bore grid	Input values	
Rectangular, no bore	<ul style="list-style-type: none"> ■ Length of base plate (1) ■ Width of base plate (2) ■ Excess length of post (7) ■ Distance of plate centre to base plate (8) ■ Selection of base plate ■ Fillet radius of corners ■ Definition of Post - Base plate connection: Post with mitre cut or distance element ■ In case of distance element: <ul style="list-style-type: none"> • with/without end cap, • Excess length of post (7) • Selection of distance element • Trim to post yes/no • Penetration of base plate yes/no 	 <p>The diagram shows a cross-section of a railing post (grey) mounted on a base plate (orange) which is attached to a blue wall. Dimension callouts are as follows: (1) indicates the length of the base plate; (2) indicates the width of the base plate; (7) indicates the excess length of the post extending above the base plate; and (8) indicates the distance from the center of the base plate to the top surface of the wall.</p>

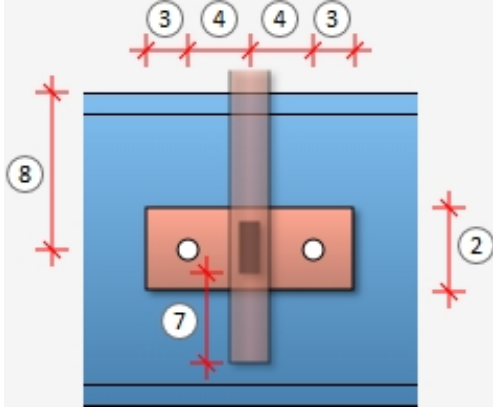
Bore grid	Input values	
Rectangular, 2 bores	<ul style="list-style-type: none"> ■ Length of base plate (1) ■ Width of base plate (2) ■ Distance of bore to plate edge in walking direction (3), ■ Bore distance, i.e. distance of bore centre to the centre of the post (4) ■ Distance of plate centre to beam (8) ■ Selection of base plate ■ Selection of distance plate ■ Selection of bolting ■ Fillet radius of corners ■ 90° rotated yes/no ■ Definition of Post - Base plate connection: Post with mitre cut or distance element ■ In case of distance element: <ul style="list-style-type: none"> • with/without end cap, • Excess length of post (7) • Selection of distance element • Trim to post yes/no • Penetration of base plate yes/no 	

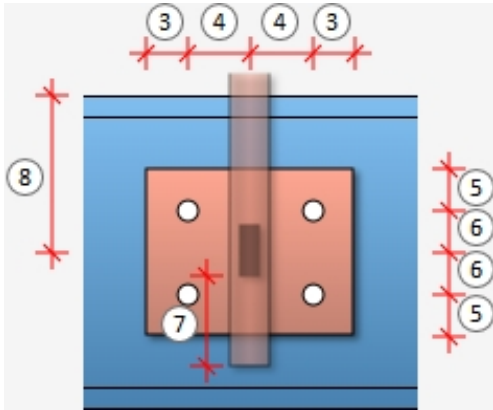
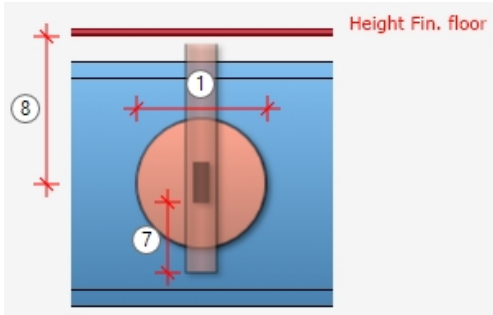
Bore grid	Input values	
Rectangular, 4 bores	<ul style="list-style-type: none"> ■ Distance of bore to plate edge in walking direction (3), ■ Bore distance, i.e. distance of bore centre to the centre of the post (4) ■ Distance of the bore centre to the centre of the post transverse to the walking direction (5) ■ Distance of bore centre to plate centre (6) ■ Distance of plate centre to beam (8) ■ Selection of base plate ■ Selection of bolting ■ Fillet radius of corners ■ Definition of Post - Base plate connection: Post with mitre cut or distance element ■ In case of distance element: <ul style="list-style-type: none"> • with/without end cap, • Excess length of post (7) • Selection of distance element • Trim to post yes/no • Penetration of base plate yes/no 	
Round, no bore	<ul style="list-style-type: none"> ■ Diameter of base plate (1) ■ Selection of base plate ■ Distance of plate centre to beam (8) ■ Definition of Post - Base plate connection: Post with mitre cut or distance element ■ In case of distance element: <ul style="list-style-type: none"> • with/without end cap, • Excess length of post (7) • Selection of distance element • Trim to post yes/no • Penetration of base plate yes/no 	

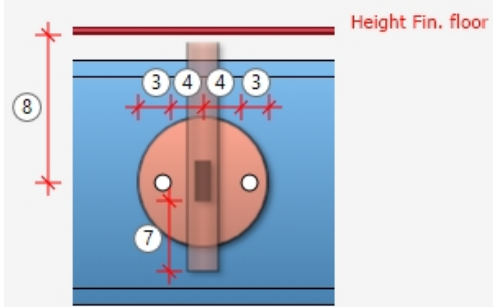
Bore grid	Input values	
Round, 2 bores	<ul style="list-style-type: none"> ■ Excess length of post (7) ■ Distance of bore to plate edge in walking direction (3) ■ Bore distance, i.e. distance of bore centre to the centre of the post (4) ■ Distance of plate centre to beam (8) ■ Selection of base plate ■ Selection of distance element ■ Selection of boltings ■ Definition of Post - Base plate connection: Post with mitre cut or distance element ■ In case of distance element: <ul style="list-style-type: none"> • with/without end cap, • Excess length of post (7) • Selection of distance element • Trim to post yes/no • Penetration of base plate yes/no 	

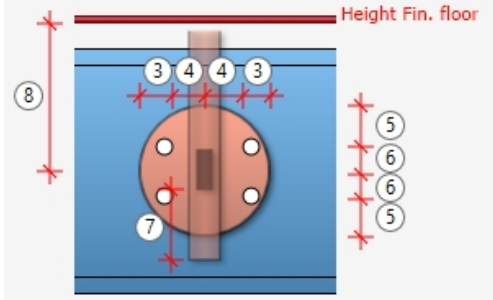
Bore grid	Input values	
Round, 4 bores	<ul style="list-style-type: none"> ■ Distance of bore to plate edge in walking direction (3) ■ Bore distance, i.e. distance of bore centre to the centre of the post (4) ■ Distance of the bore centre to the centre of the post transverse to the walking direction (5) ■ Distance of bore centre to plate centre (6) ■ Distance of plate centre to beam (8) ■ Selection of base plate ■ Selection of bolting ■ Definition of Post - Base plate connection: Post with mitre cut or distance element ■ In case of distance element: <ul style="list-style-type: none"> • with/without end cap, • Excess length of post (7) • Selection of distance element • Trim to post yes/no • Penetration of base plate yes/no 	

 Depending on the kind of the selected beams they will be divided into different sections. The first beam belongs to section 1. HiCAD checks whether the next beam lies on the same plane. If so, it also belongs to section 1. If it does not lie on the same plane, section 2 will start with this beam and so forth. For the lateral post connection the **Distance, plate centre** can be set individually for each section. If the distance should be the same for all areas, activate the **All same** checkbox.

There are two new possibilities available for connecting posts and base plates:

■ **Post mitre cut**

Instead of a distance plate, the same beam as for the post will be generated and a mitre cut will be applied to the newly created beam and the post beam.

■ **Distance element**

A distance element for the post beam and - if desired - an end cap will be installed. The excess length of the post can be determined. If the distance element should be trimmed to the post, the respective checkbox has to be activated and the width of the obtuse end has to be entered.

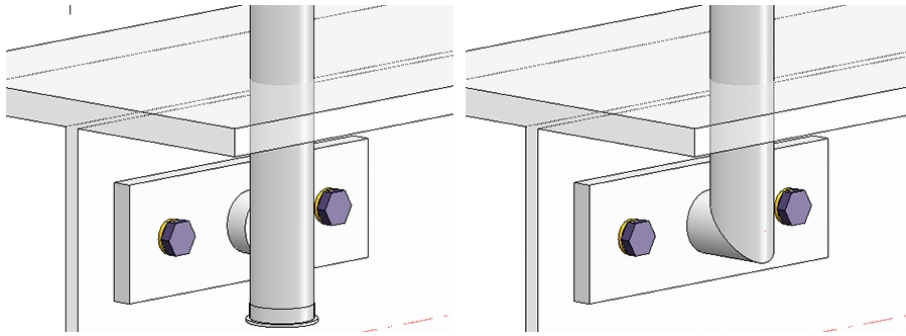

Left: with distance element (trimmed) and end cap, right: post mitre cut

If the connection is made with a distance element, there is a possibility that the distance element penetrates the base plate when connecting laterally. To do this, activate the checkbox **Penetration of base plate** and specify the **Clearance**, the **Corner radius** and the **Shortening of distance element**.

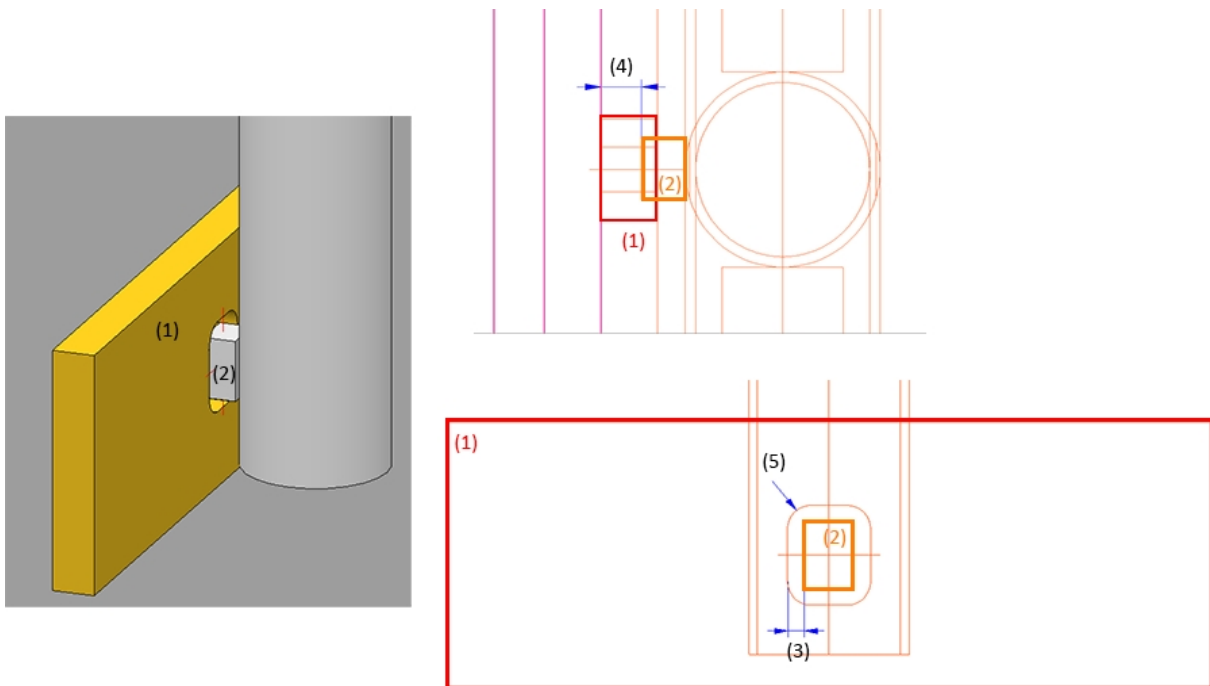

(1) Base plate, (2) Distance element, (3) Clearance, (4) Offset, (5) Corner radius

Connection from bottom

Inputs for Connection from bottom

- Post

Variant: Connection from bottom

Width (1): 200

Length (2): 300

Length (3): 100

Rotate cross-section 90°:

Base plate: BI 12 - S235JR

Bore distance (4): 25

Bore distance (5): 50

Bore distance (6): 25

Bore distance (7): 50

Diameter (8): 13

Insert standard parts:

Anchor (3-D): HSA M12x85 5/-/- - St

Washer: ISO 7090-12-200 HV-St - St

Nut: ISO 4032-M12-6 - 6

Layer for auxiliary points: 0

- Corner post (on the 'Post distribution' tab, activate 'Create corner posts checkbox')

Variant: <Do not create>

Specify the following values:

Inputs	
■	Widths and lengths of the connection (1) to (3)
■	Rotate cross-section 90° yes/no
■	Selection of base plate
■	Bore distances (4) - (7)
■	Diameter of bore (8)
■	Insert standard parts yes/no; if you choose yes , select the standard parts
■	Layer for auxiliary points If you want to assign the auxiliary points for the standard parts to a particular layer, you can specify the number of the layer here. The default setting is Layer 0.

Connection from bottom with flat steels

Inputs for Connection from bottom with flat steels

- Post

Variant: Connection from bottom with flat steels

- General

Length (1) 250

Depth (2) 150

Projection below (3) 5

- Flat steel

Material FI 80x10 - S235JR

Angle (4) 0

Edge distance (5) 5

- Base plate

Material BI 16 - S235JR

Bore diameter (6) 13

Distance (7) 50

Distance (8) 100

Distance (9) 30

Distance (10) 60

Fillet radius (11) 0

- Standard Parts

Insert standard parts

Anchors HSA-F M12x100 20/5/

Washer ISO 7090-12-200 HV-S

Nut EN 14399-3-M12-8-Hf

Specify the following values:

Inputs

- Length (1) and Depth (2) of the connection
- Projection below (3)
- Selection of flat steel
- Angle (4) and Edge distance (5)
- Selection of base plate
- Distances between bores (7) - (10)
- Bore diameter (8)
- Fillet radius (11)
- Insert standard parts yes/no; if you choose **yes**, select the standard parts



Lateral connection with flat steels

Inputs for the Lateral connection with flat steels

- Start, intermediate, end posts

Variant: Lateral connection with flat steels

Number of bores : 2

Distance (1): 40

Distance (2): 100

Width (3): 60

Excess length of post (4): 150

Create: Double-sided

Connecting sheet BI 10 - S235JR

Bore diameter 10

- Boltings

Fit Invert

Create bores

Settings DIN EN 14399-3-M12-8.8

- Corner post (on the 'Post distribution' tab, activate 'Create corner posts checkbox')

Variant: <Do not create>

The following must be specified:

Inputs

- Number, diameter, spacing and distance of bores (1),
- Distance of the connecting plate from the bottom edge of the post (2),
- Width of the connecting plate (3),
- Excess length of the post (4), i.e. distance from the bottom edge of the post to the finished floor,
- Selection of whether the connecting plate is to be created on the left, right or both sides and
- Selection of the connecting plate (sheet metal or flat steels).
- Boltings
Here you determine whether the bolting is to be inserted or only the bores. The bolting can be put together with a click on . The determination is made in the same way as for the Steel Engineering Bolting function. If the bolting is to be inverted, activate the **Invert** checkbox.

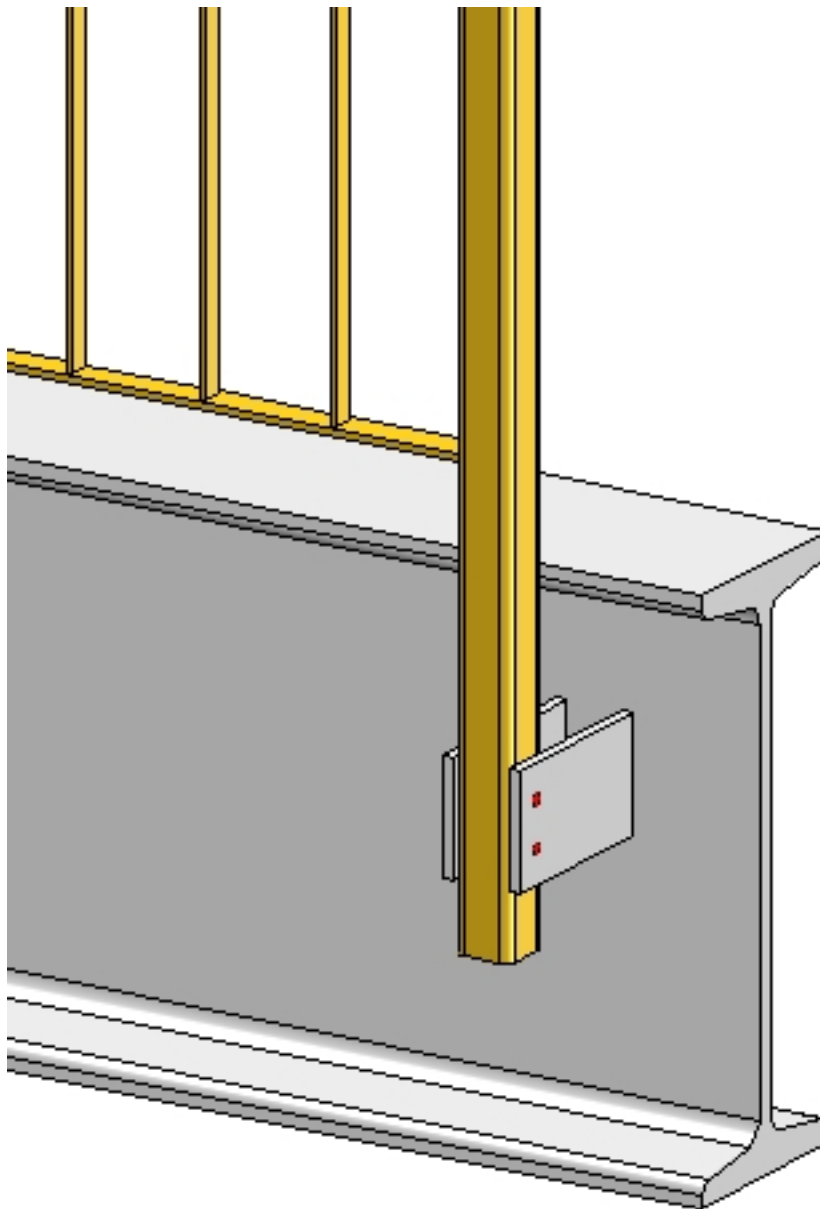

Corner post connection

If you have activated the **Create corner posts** checkbox on the **Post distribution** tab, you can specify the corner post connections here (with the exception of the Post connection, top). The following variants are possible:

- Do not create
- Connection from bottom with flat steels
- Corner post connection, lateral

Value inputs for Corner post connection, lateral

- Corner post (on the 'Post distribution' tab, activate 'Create corner posts checkbox')

Variant: Corner post connection, lateral

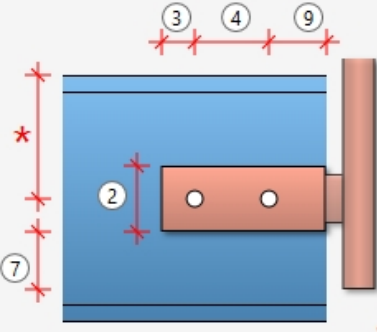
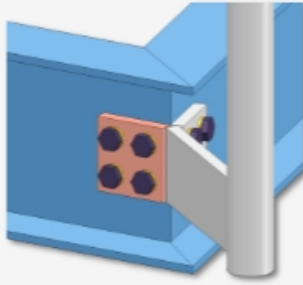



* See Parameter 8 for 'Post'

- Base plate

Base plate: BI 14 - S235JR

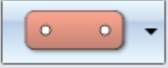
Boltings: DIN EN 14399-3-M12-8.8



(3) 40 (2) 100

(4) 75

(9) 50

- Connection Post-Base plate

Post mitre cut Distance element

Distance element: FI 50x15 - S235JR

End cap, post: End cap-48.3x2.6 (Convex)

(7) Excess length of post: 20

Trim to post 0 ⓘ

Depending on the selected bore grid, the possible options are:

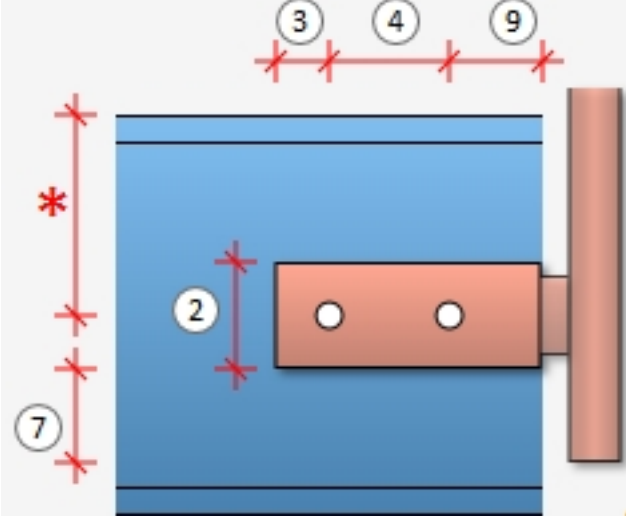
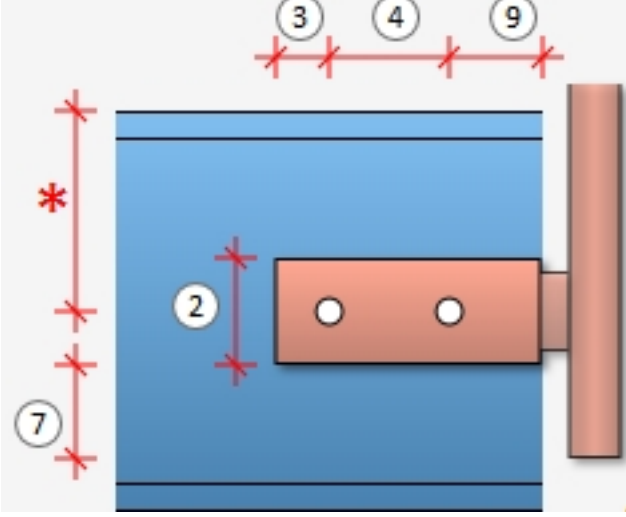
Bore grid	Input values	
No bore	<ul style="list-style-type: none"> ▪ Length of base plate (1) ▪ Width of base plate (2) ▪ Excess length of post (7) ▪ Selection of base plate ▪ Definition of Post - Base plate connection 	
2 bores	<ul style="list-style-type: none"> ▪ Width of base plate (2) ▪ Distance of 1st bore (centre) to left edge of base plate (3), ▪ Distance between the bores (4) ▪ Distance of 1st bore (centre) to right edge of base plate (9) ▪ Excess length of post (7) ▪ Selection of base plate ▪ Selection of bolting ▪ Definition of Post - Base plate connection 	

Bore grid	Input values	
4 bores	<ul style="list-style-type: none"> ▪ Distance of 1st bore (centre) from left edge of base plate (3), ▪ Distance between the bores (4) ▪ Distance of 2nd bore (centre) to right edge of base plate (9) ▪ Distance of bore to upper-/lower plate edge (5) ▪ Distance of bore centre to plate centre (6) ▪ Excess length of post (7) ▪ Selection of base plate ▪ Selection of bolting ▪ Definition of Post - Base plate connection 	<p>The diagram illustrates a cross-section of a railing post (orange) connected to a base plate (blue). The base plate consists of an upper and lower section. A red square represents the post's base, which is bolted to the upper section of the base plate. Dimension lines with arrows indicate the following measurements: (3) is the distance from the left edge of the base plate to the center of the first bore; (4) is the distance between the centers of two adjacent bores; (9) is the distance from the center of the second bore to the right edge of the base plate; (5) is the distance from the center of a bore to the top and bottom edges of the base plate; (6) is the distance from the center of a bore to the center of the base plate; and (7) is the excess length of the post extending beyond the base plate.</p>

For the connection of posts and base plates the same options are available as for "normal" post connections.

Please note:

Even if you activate the **All posts equal** checkbox on the **Post** tab, the settings on the tabs **Post - Sub-structure** and **Post - Handrail** will not be considered for corner posts and transition posts! The connections on corner posts and transition posts must therefore be reworked manually.

Post - Handrail

Here you specify the connection of post and handrail.

Value inputs for the connection of post and handrail

All connections equal

- Start post - Handrail

Variant:

Material of connecting pipe:

Type of connecting pipe:

- Intermediate post - Handrail

Variant:

At lower edge of handrail

Width of obtuse end: 

- End post - Handrail

Variant:

Material of connecting pipe:

Type of connecting pipe:

- Corner post - Handrail (must have been activated on 'Post distribution' tab)

Variant:

If you want to use the same variant for all posts, please activate the **All posts equal** checkbox.

Allowed connections			
Start post - Handrail (3)	Intermediate post - Handrail (2)	Corner post - Handrail (2)	End post - Handrail (4)
<ul style="list-style-type: none"> ■ Mitre cut ■ Trim pipes ■ Connect pipes ■ Connection with mandrel ■ Start arc ■ End arc ■ Console ■ Console (round bar) ■ Wall console (Own production) ■ Wall console (Pre-fabricated part) 	<ul style="list-style-type: none"> ■ Trim pipes ■ Connection with mandrel ■ Start arc ■ End arc ■ Console ■ Console (round bar) ■ Wall console (Own production) ■ Wall console (Pre-fabricated part) 	<ul style="list-style-type: none"> ■ Trim pipes ■ Connection with mandrel ■ Start arc ■ End arc ■ Console ■ Console (round bar) ■ Wall console (Own production) ■ Wall console (Pre-fabricated part) 	<ul style="list-style-type: none"> ■ Mitre cut ■ Trim pipes ■ Connect pipes ■ Connection with mandrel ■ Start arc ■ End arc ■ Console ■ Console (round bar) ■ Wall console (Own production) ■ Wall console (Pre-fabricated part)

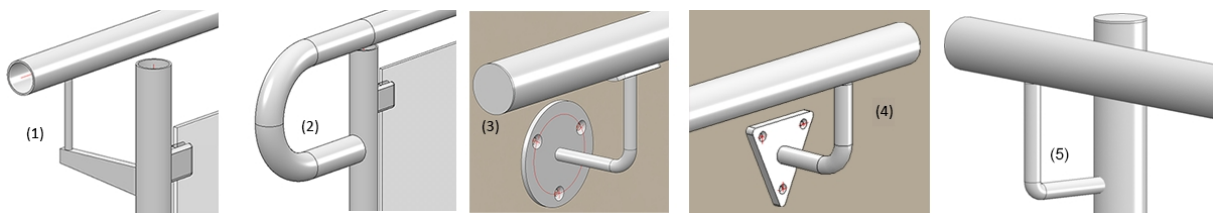

Example 1- (1) Console, (2) Start arc, (3) Wall console (Prefabricated part), (4) Wall console (Own production), (5) Console (round bar)

The **At lower edge of handrail** checkbox is also available for the **Trim pipes** variant. If the post is to be cut straight at the lower edge of the handrail, activate this checkbox.

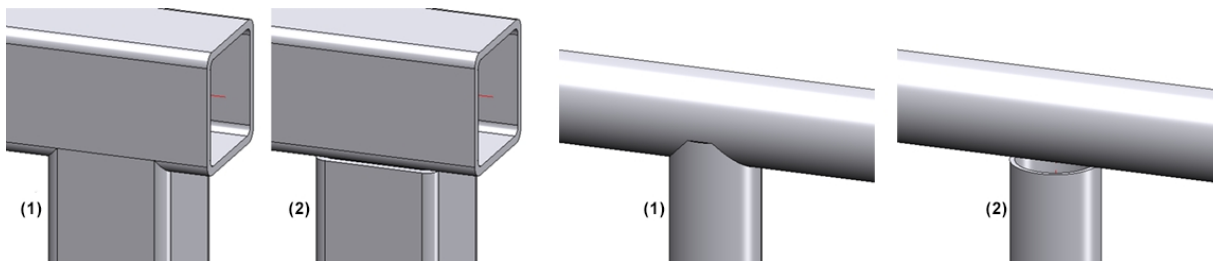

(1) Trim pipe, (2) Trim pipe, at lower edge of handrail

Wall console

To create the wall console, the corresponding settings on the tabs

- Post,
- Infill and
- Post-Sub-structure

must be set to **Do not create** or **Do not insert**, respectively. In addition, a lateral offset to the handrail must be entered on the **Post** tab.



The following has been preset for the bores on the prefabricated element:

- Bores for handrail mounting: Countersink DIN 66, size 5

- Bores for wall mounting: Countersink DIN 74-1 F, size 6

If you want to preset other drillings, you can do this by changing the table **Factory standards > Purchased/Factory standard parts > Railing > Wall consoles > Prefabricated brackets** (RAILING_BRACKET_29_ISD.IPT). There you have to change the columns

- **CS_CAT_ITEM** (Bore for handrail mounting) and
- **W_CAT_ITEM** (Bore for wall mounting)

accordingly.

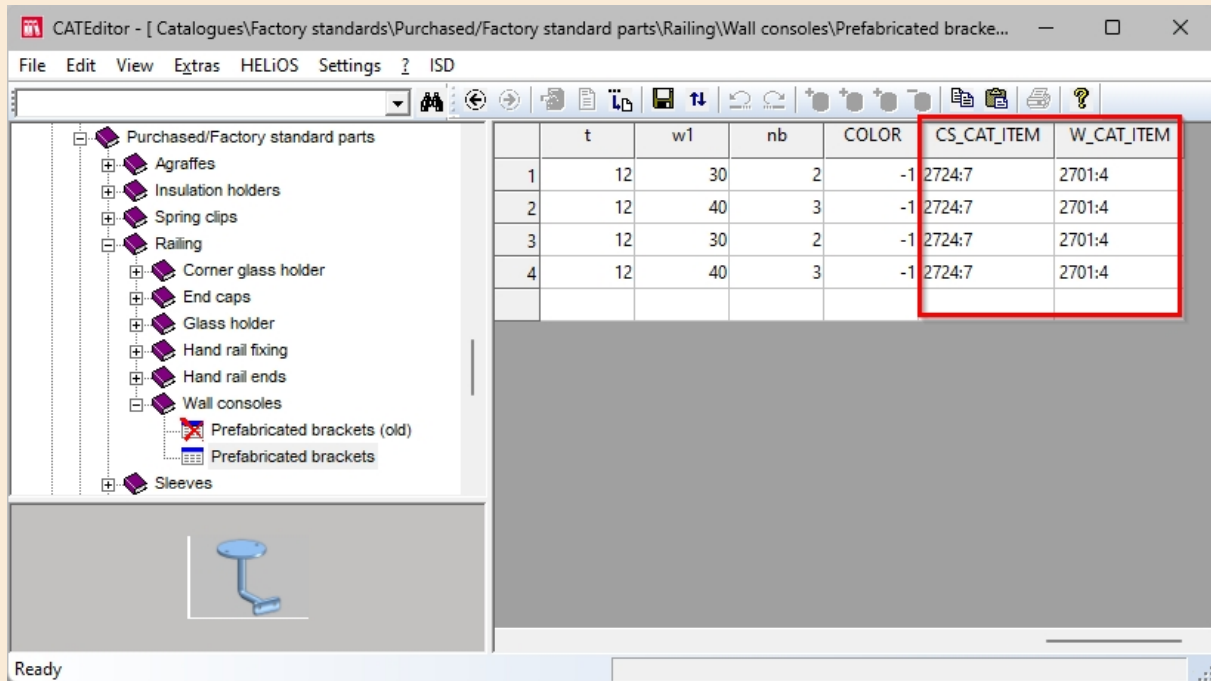

The first value in each case is the table ID, the second value is the ID of the corresponding data record. The two values are separated by a colon. For example, **2724:7** stands for the table **DIN 66** at **Processings, general > Processing > Countersink** and the data record with the **ID 7**. If you double-click with the cursor in one of the columns, you can directly select the desired table and data record.

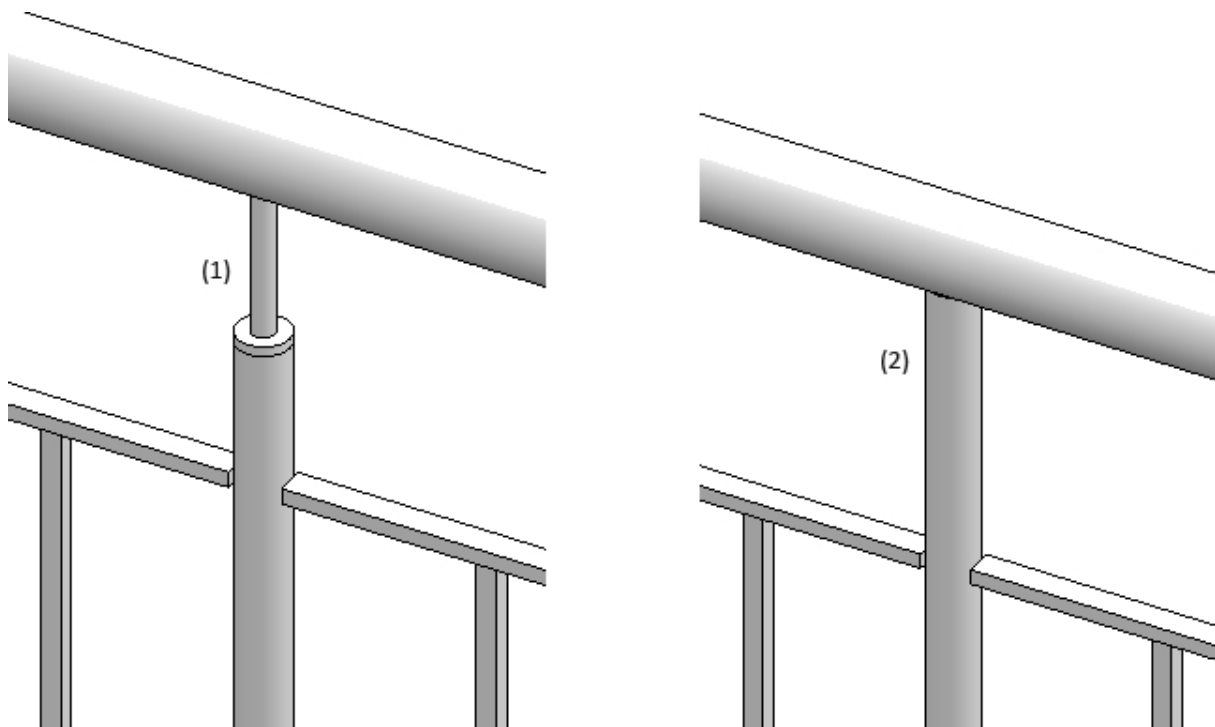

Example of a connection Intermediate post - Handrail: 1) Connection with mandrel, (2) Trim pipes

For the **Connect pipes** variant you need to choose the material for the connecting pipe and then its type. The latter determines the bend radius:

- 2 (Bend radius approx. 1,0 x Outer diameter)
- 3 (Bend radius approx. 1,5 x Outer diameter)
- 5 (Bend radius approx. 2,5 x Outer diameter)
- 10 (Bend radius approx. 5 x Outer diameter)
- 20 (Bend radius approx. 10 x Outer diameter)

For round to round connections the parameter **Width of obtuse end** can be specified if the **Trim pipes** option has been selected. Normally, a pointed end (1) is created on the pipe after the trimming. Use the **Width of obtuse end(2)** parameter to specify how the pointed end on the post is to be cut off.

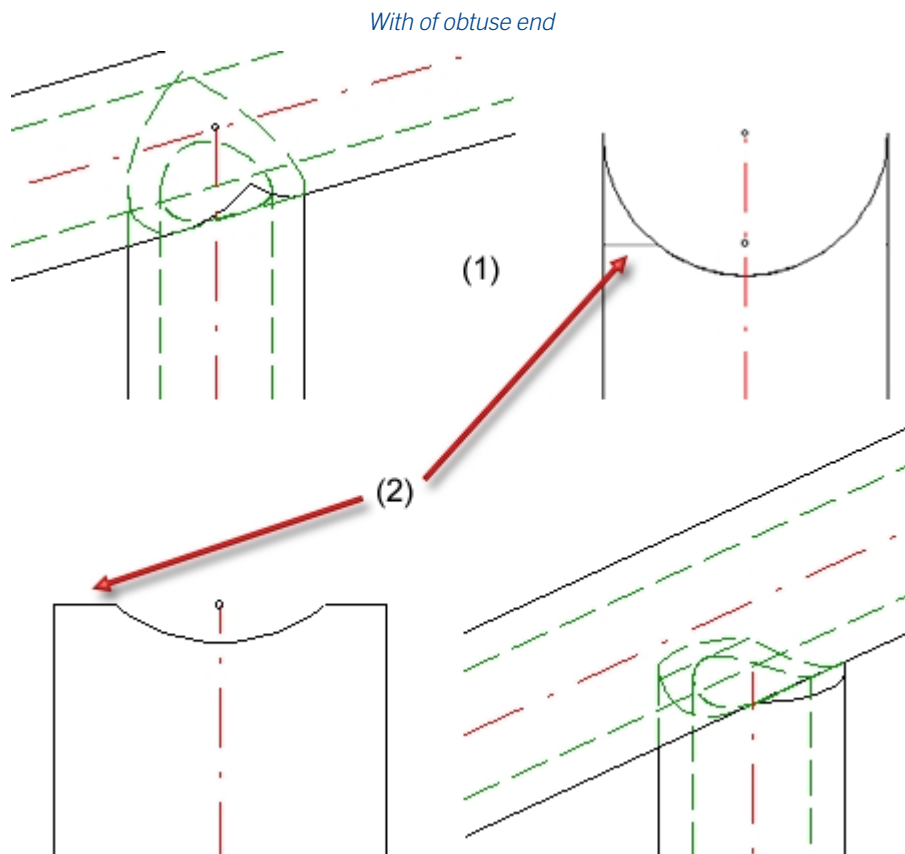

Please note that a connection of corner posts and handrails is only possible if the **Create corner posts** check-box has been activated on the **Post distribution** tab.

Handrail - Handrail

Here you define the connection of the handrails.

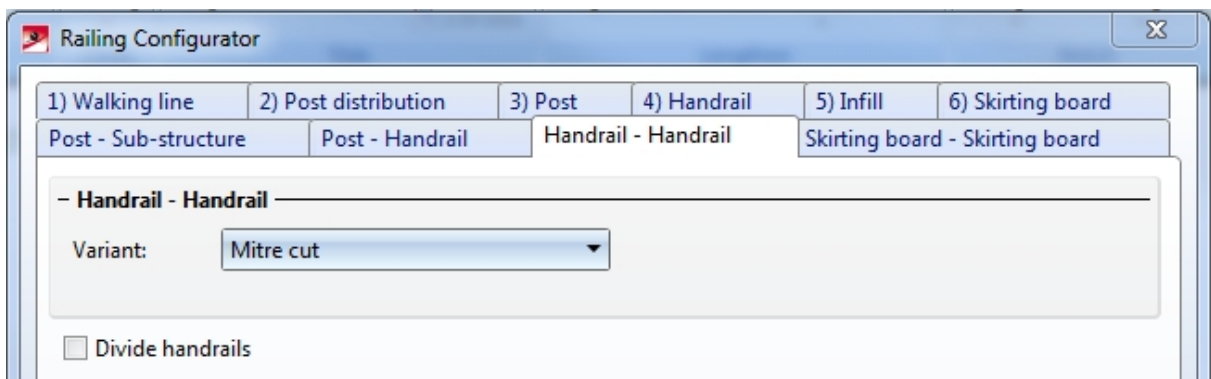

Allowed connections are:

- Mitre cut,
- Connect pipes.

Variants:

Material of connecting pipe:

Type of connecting pipe:

Handrails can also be divided, e.g. in order to insert plug-in profiles or flat steel joints for long railings. Just activate the required checkbox.

If the checkbox is active, the variant for handrail division and the division of the handrail can be specified by segments.

- Handrail - Handrail

Variant: Mitre cut

Divide handrails

- Variant for handrail divisions

Variant: Plug-in profile

The diagram shows a cross-section of a handrail joint. Two cylindrical sections are joined at a central point. Dimension lines indicate two segments of length '1' on either side of the joint, and a central gap of length '2'.

Plug-in profile: FI 25x8 - S235JR

Length 1(1): 50

Clearance(2): 5

Rotate cross-section 90°:

Layer for auxiliary points: 0

- Division distances

Segment 1 (Straight line length = 3000)

The divisions can be defined either by specifying the distance from the segment start, or by specifying a division point.

+	<p>New division Click on this symbol to add a new division, e.g.:</p> <div style="border: 1px solid #ccc; padding: 5px; margin-bottom: 10px;"> <p>- Division distances -</p> <div style="border: 1px solid #ccc; padding: 5px; margin-bottom: 5px;"> <p>Segment 1 (Straight line length = 3000) +</p> <p>Distance segment start: <input type="text" value="750"/> ✕</p> </div> </div> <div style="border: 1px solid #ccc; padding: 5px;"> <p>- Division distances -</p> <div style="border: 1px solid #ccc; padding: 5px; margin-bottom: 5px;"> <p>Segment 1 (Straight line length = 3000) +</p> <p>Distance segment start: <input type="text" value="750"/> ✕</p> <p>Distance segment start: <input type="text" value="1500"/> ✕</p> </div> </div> <p style="text-align: center; margin-top: 10px;">↓</p> <p>Enter the distance of the division from the segment start in the input field.</p>
+	<p>New division at selected point Click on this symbol to define the division by specifying a division point.</p>

Divisions can be deleted at any time by clicking on the  symbol at the top right next to a division.

The following variants for handrail division have been predefined:

- Straight cut,
- Plug-in profile and
- Flat steel joint.

The image below shows a railing with divided handrails.

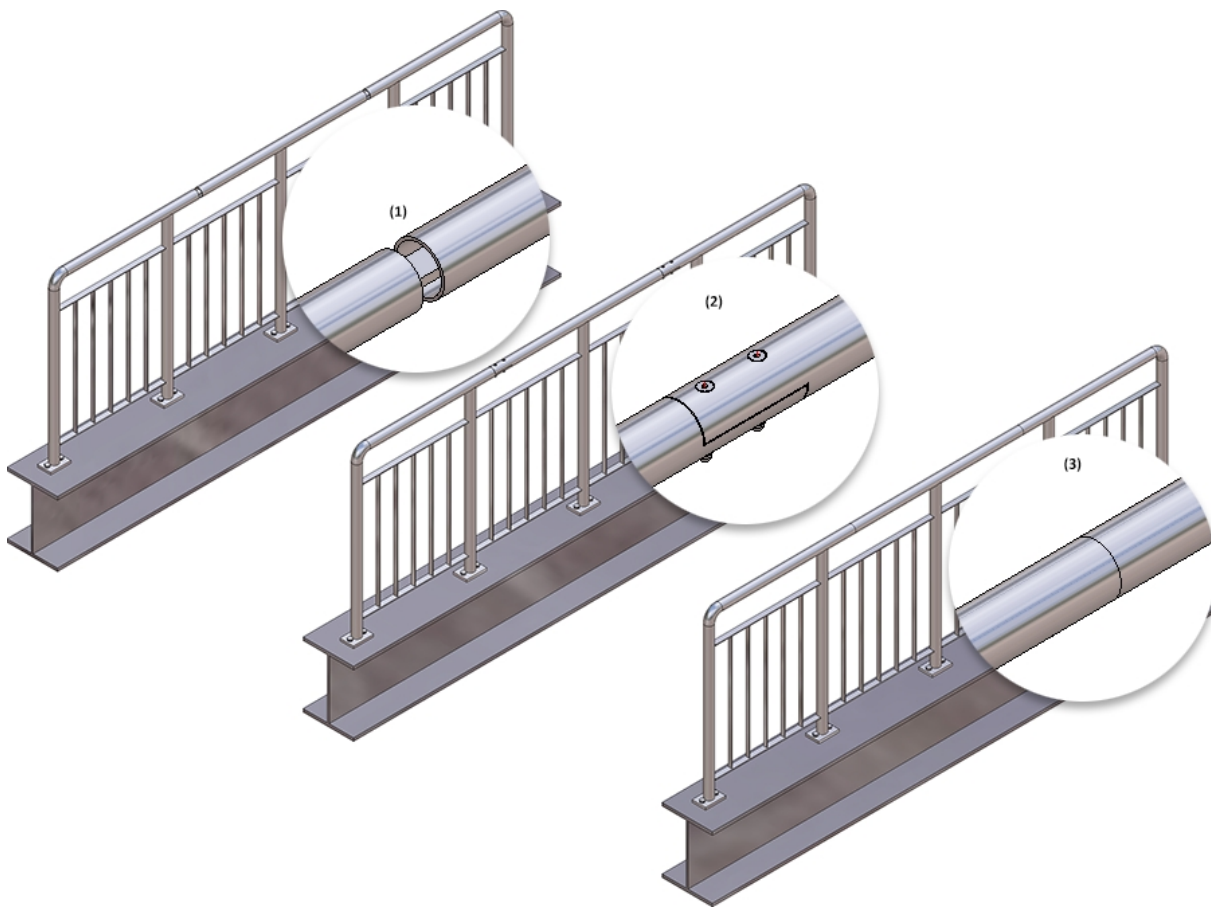

(1) Variant: Plug-in profile, (2) Variant: Flat steel joint, (3) Variant: Straight cut

Skirting board - Skirting board

Here you define the connection of the skirting boards. Here, mitre cuts are possible.



Example, Step 4 - Selection of connections

Use the ISD default settings and close the dialogue window with **OK**. The first railing will be inserted.

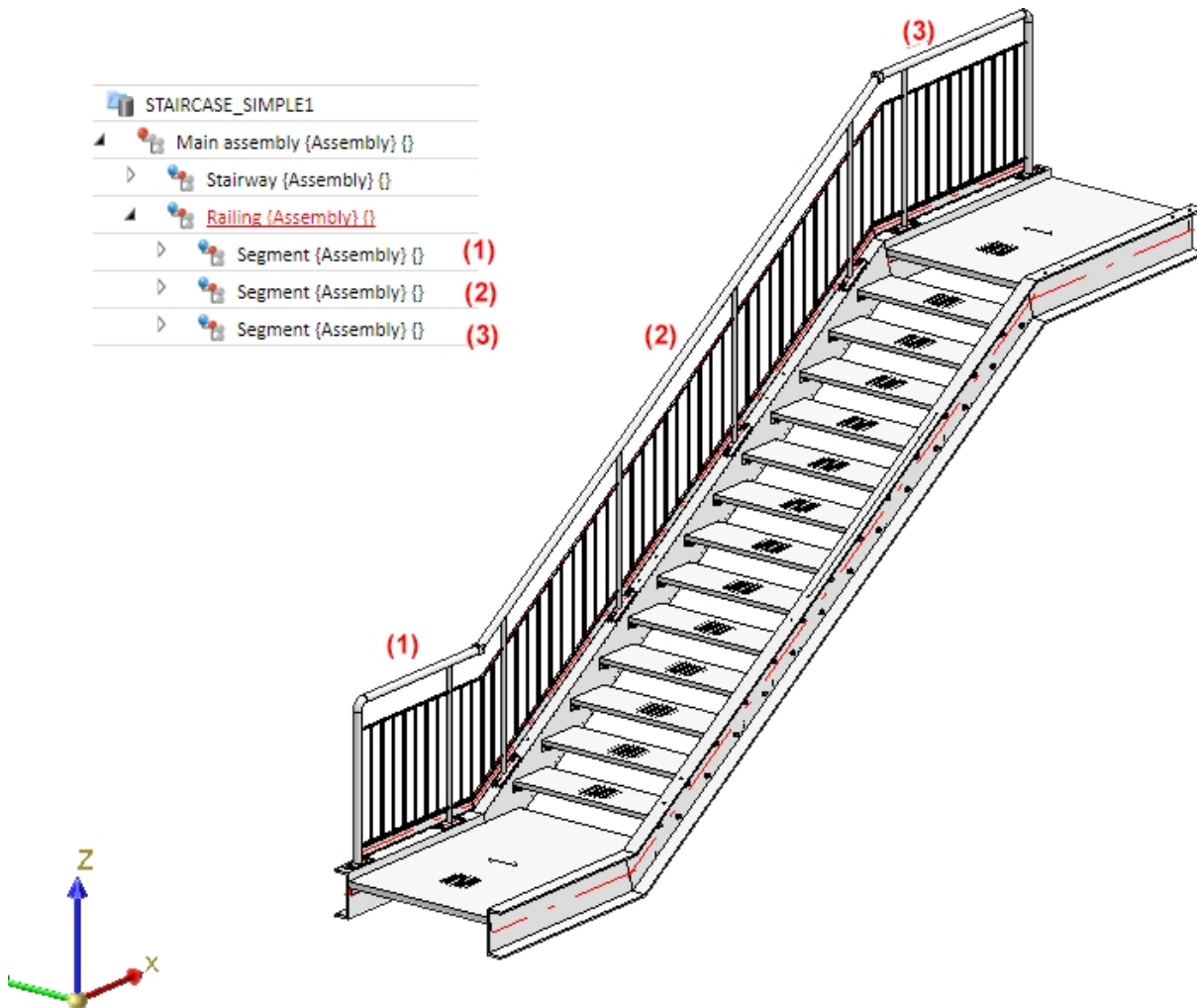



Example, Step 5 - Repeat Step 1 to Step 4 for the right stair stringer

Complete the example by repeating Steps 1 to 4 for the right stair stringer. Call the railing Configurator again and identify the right stringer beams (1) and (2).

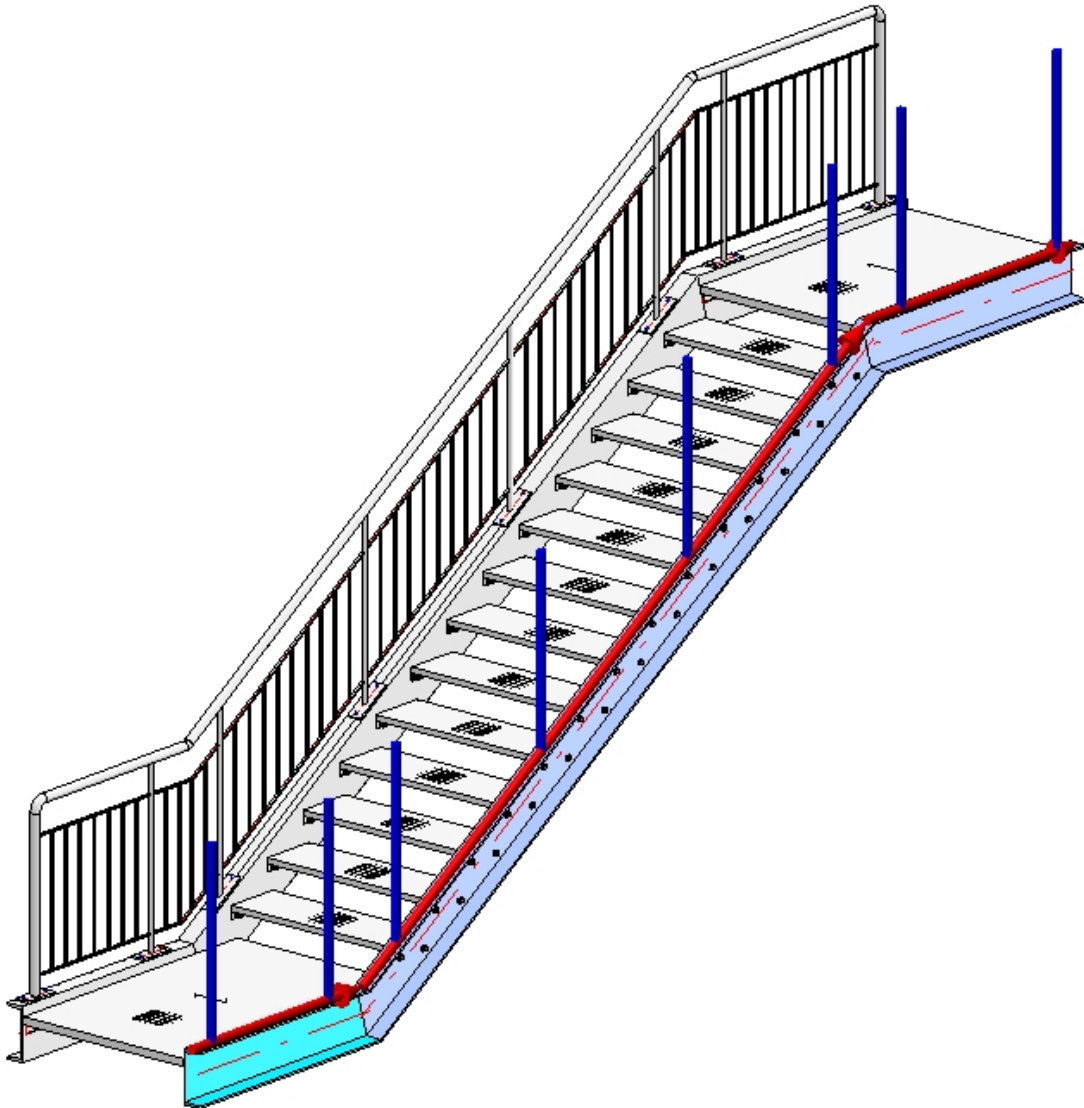

The last chosen parameters will be shown in the Railing Configurator dialogue window. With the exception of the Offset, which needs to be entered in negative Y-direction here, apply all of those settings by clicking **OK**. The railing will then be generated.

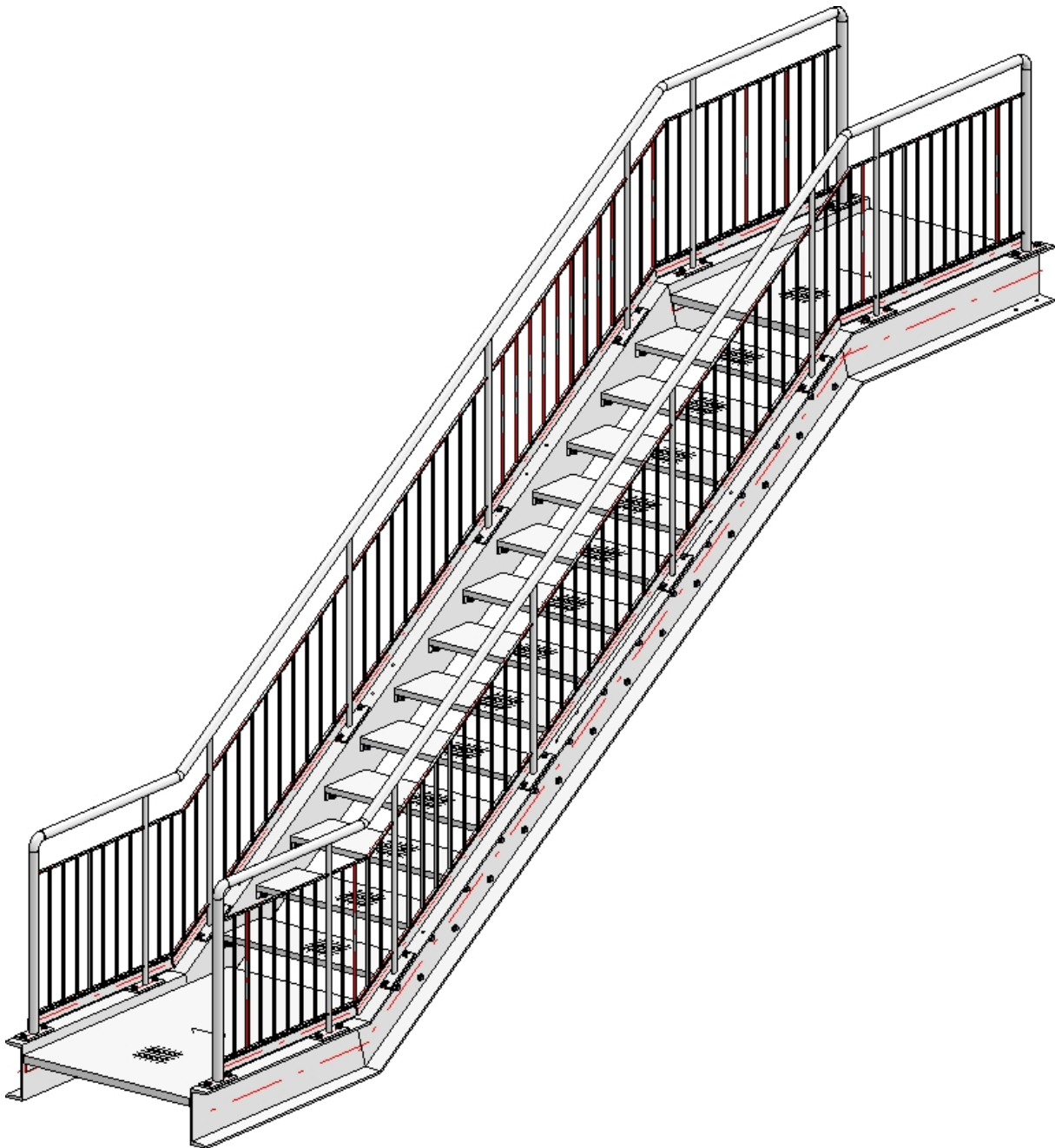

Finished railing

An example and tips for the placing of railings with equal post distances on multi-storey staircases can be found [here](#).

Railing Configurator - Process Railing

'Civil Engineering functions' docking window > Steel Engineering > Stairs + Railings > Railing > Railing Configurator

To process an already existing railing, identify one of the railing elements and double-click the **Railing along edges** or the **Railing along beams** item in the feature log. The Railing Configurator will be displayed.

If you apply manual changes which are based on features to the elements of a railing, e.g. insert a bore or a material subtraction in a steel beam, or fillet the corners of a square profile, HiCAD will try to preserve these manual changes when the railing is updated or modified, provided that they still make sense.

Example:

The image below shows the detail of railing that has been created with the Railing Configurator (1). Manual changes were then applied to this railing (2): Slots were inserted in the post and the post end was filleted. The railing was then processed further with the Railing Configurator, where a different infill was selected (3). The manually applied changes were preserved in the process.

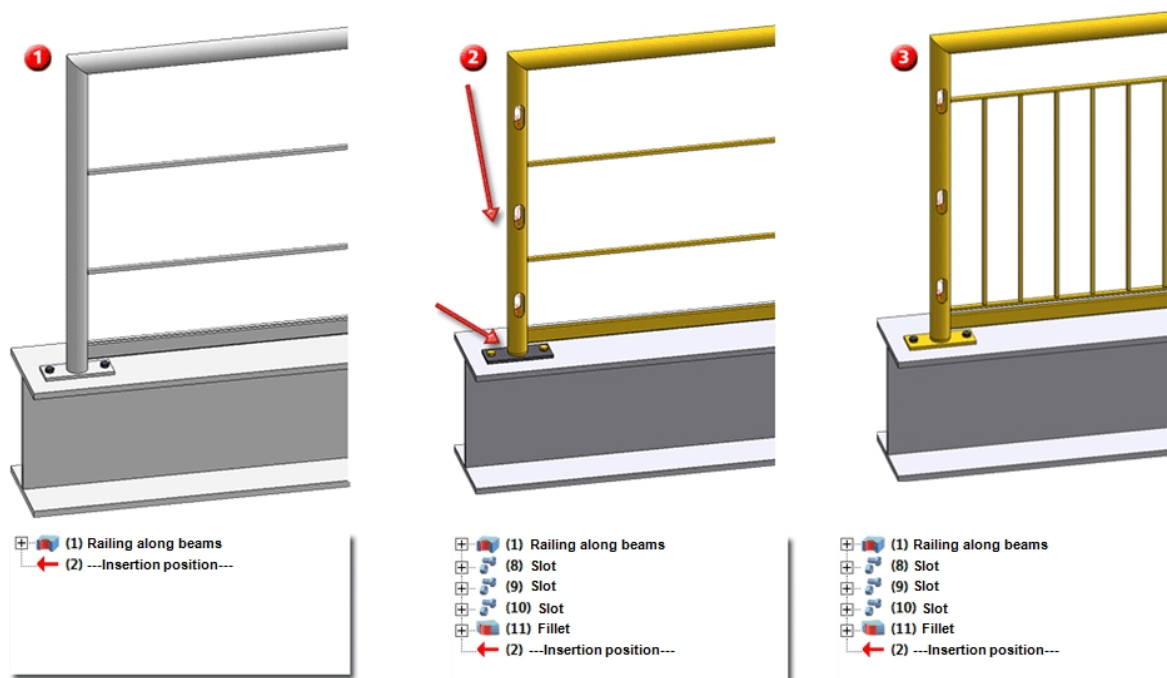

If the beams on which the railing was placed are modified (lengthened, exchanged etc.) after the generation of the railing, you can update the railing by right-clicking the corresponding feature log entry and selecting **Update** in the context menu. The railing will then be adjusted accordingly. The same applies to railings along edges. Here, the same conventions as for the selection of edges apply (the same edges must form, in the same order, a continuous path with intersections points at the junctions).

To delete a railing, either delete the feature **Railing along edges** or **Railing along beams**, or use the Delete connection function (**Steel Engineering > Variants**).



Please note:

Variants created with the Railing Configurator can now be broken up (resolved). This makes sense if manual adjustments are required after the automatic creation of a railing. You can then use the Steel Engineering functions for this purpose.

To break up the variant, right-click the name of the **Railing...** variant in the feature log and select **Break up variant**. The successful breaking up of the variant is indicated in the feature log by means of the additional feature text **(resolved)**. The breaking up automatically switches off the bolting feature **Assembly...**. This allows you to process the boltings by means of the "normal" 3-D bolting functions. If you require the bolting feature again later, e.g. in order to continue working with HCM constraints, it can be switched on again at any time.

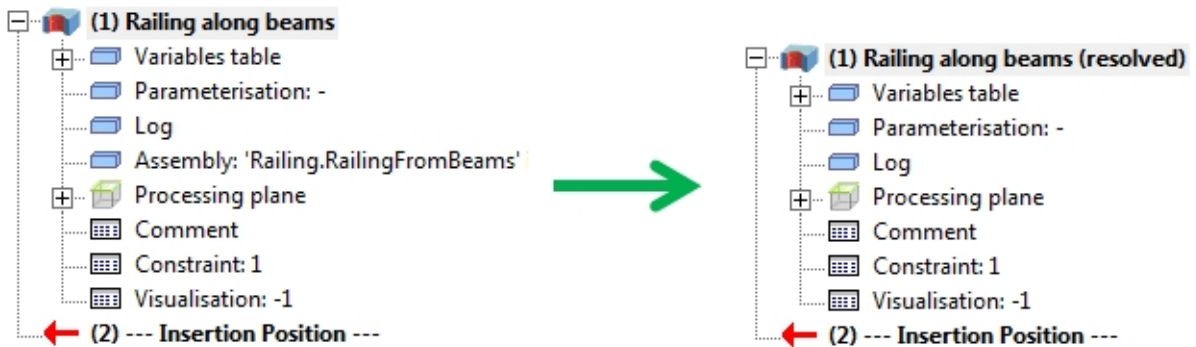

Multi-Storey Stairs + Railings with Equidistant Posts

Civil Engineering functions docking window > Steel Engineering > Stairs + Railings > Railing > Railing Configurator (Railings along beams)

A frequent case in practice is the placing of railings onto multi-storey staircases with equidistant posts. All posts are to be located below one another (with regard to the storey), and parallel to one another (with regard to the staircase sections), respectively. Here, the post configuration in the **Railing Configuration** dialogue window will play an important role.

This will be illustrated by means of the following example of a multi-storey staircase.

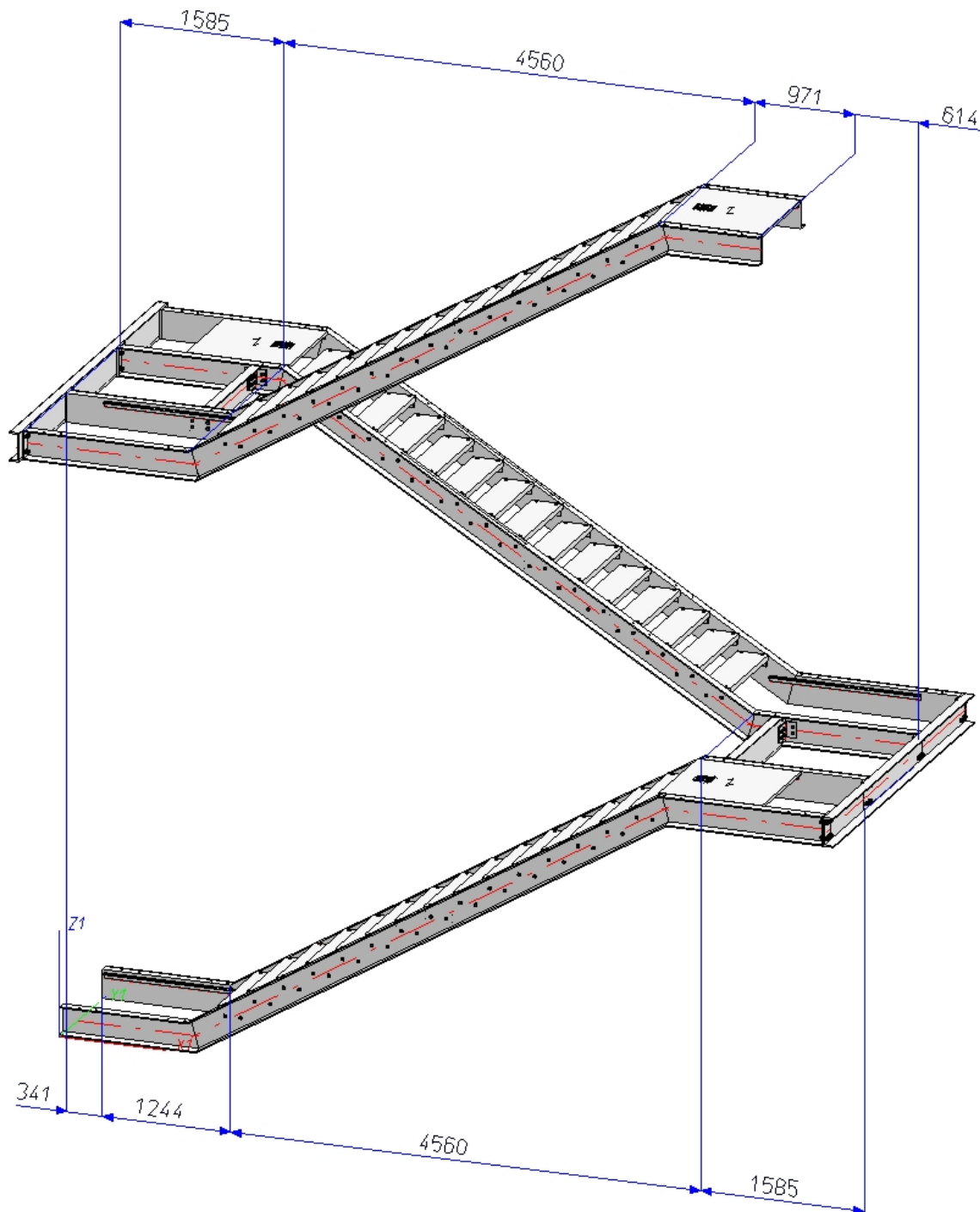

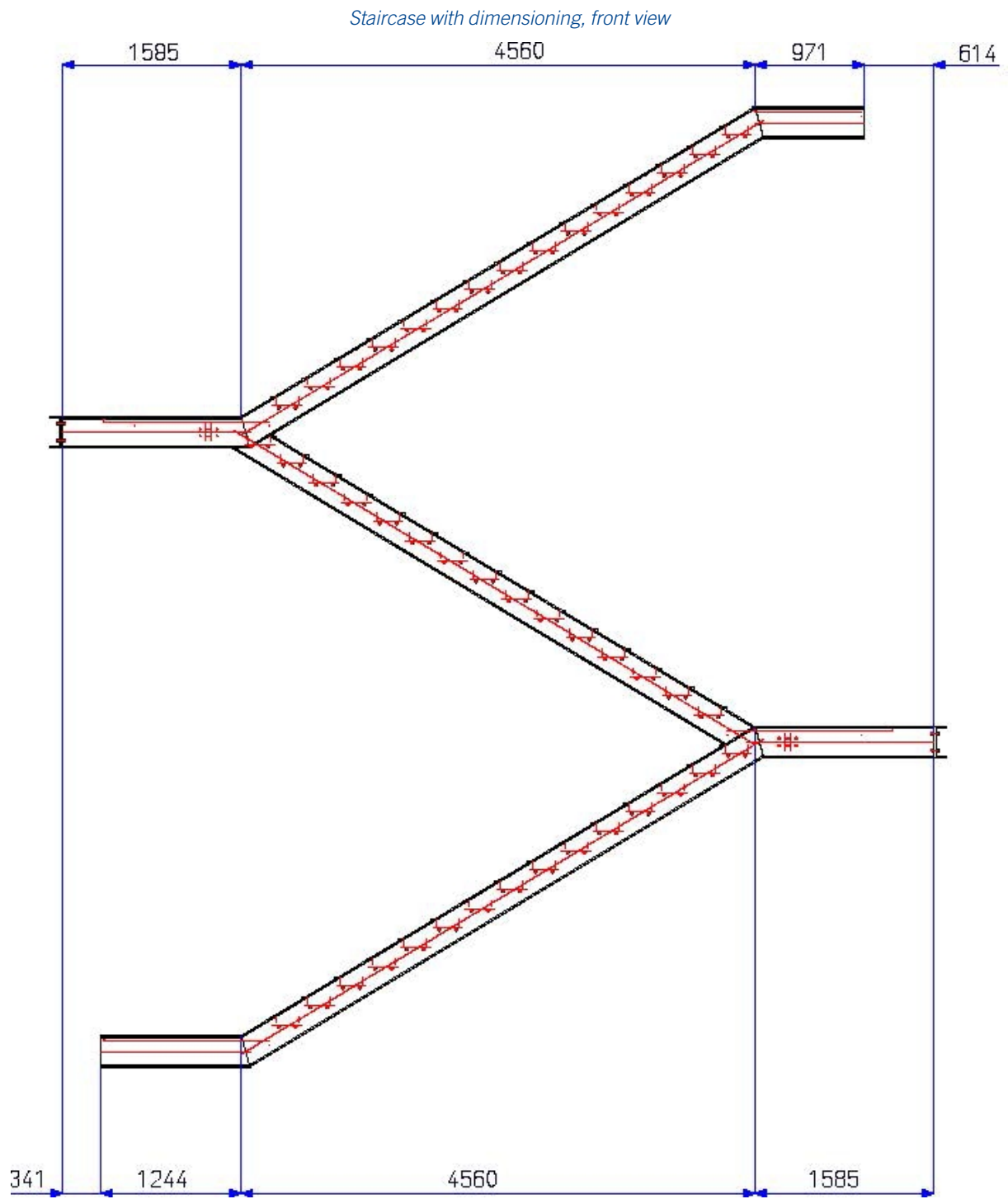

A railing is to be mounted to this staircase as shown below:

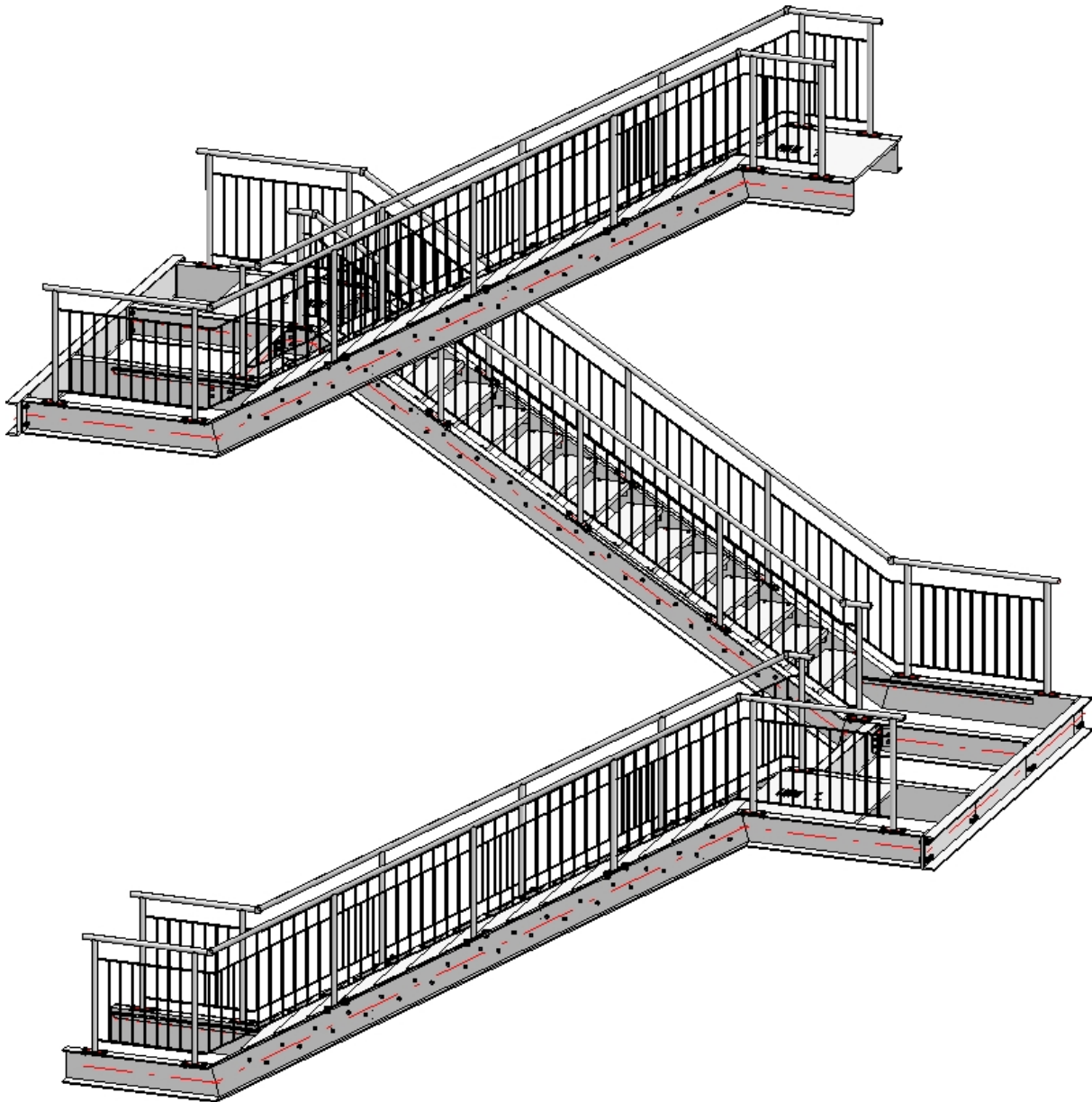

Important:

During configuration of the staircase you already need to have a rough idea of what the railing will look like. If the posts of the railing are to be located perpendicular below one another, the transitions (inflexion points) of the walking lines of the staircase must be located one above another.

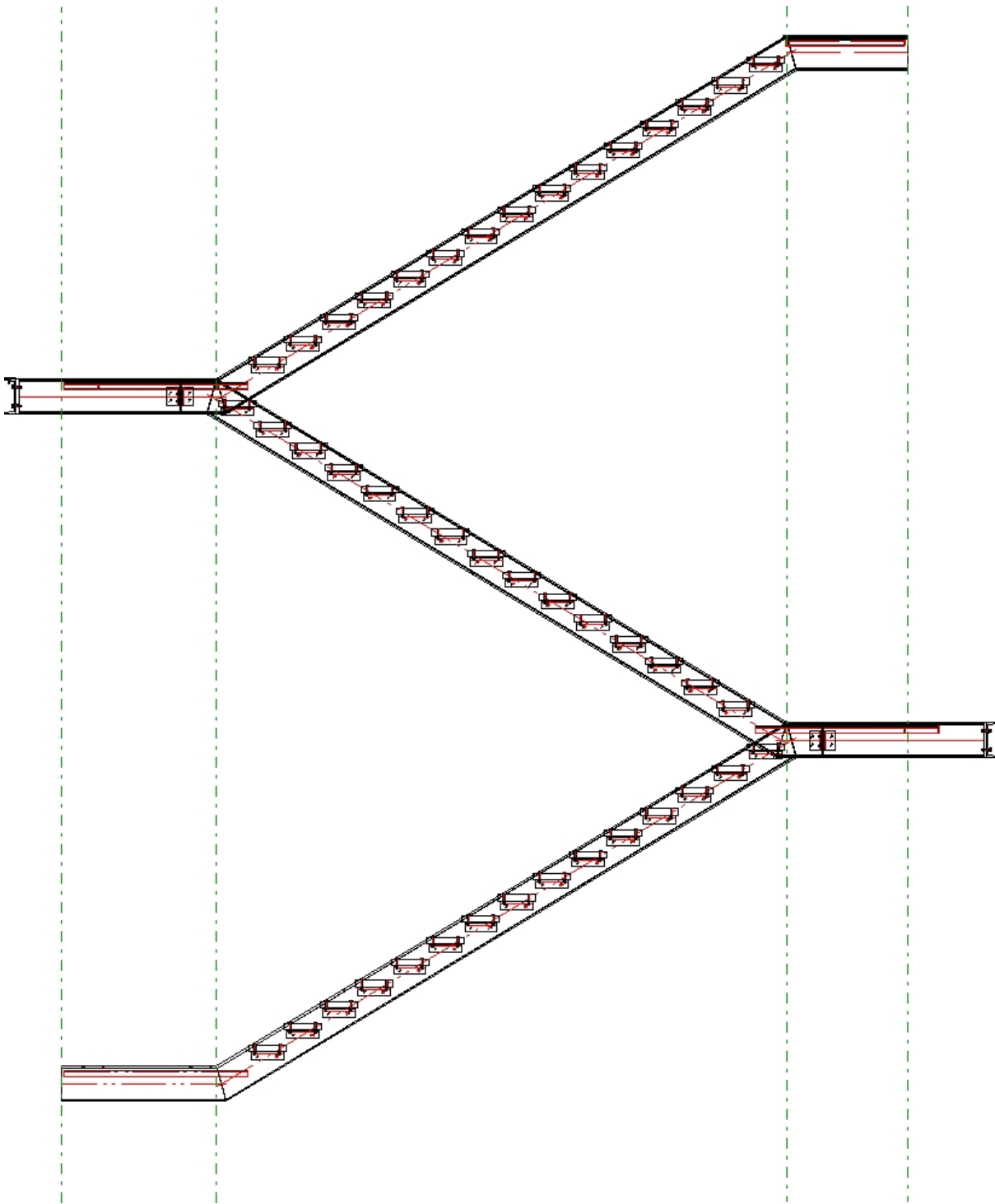

For this example, the settings on the **Post distribution** tab of the Railing Configurator dialogue window play a crucial role. For the easiest handling you should not work with maximum post distances, but use the other options instead. Furthermore, the distribution of posts should not take place by segments, but across the entire area. The Dimensions 4 and 5 (Corner distance and Transition distance) will therefore not be evaluated in this example.

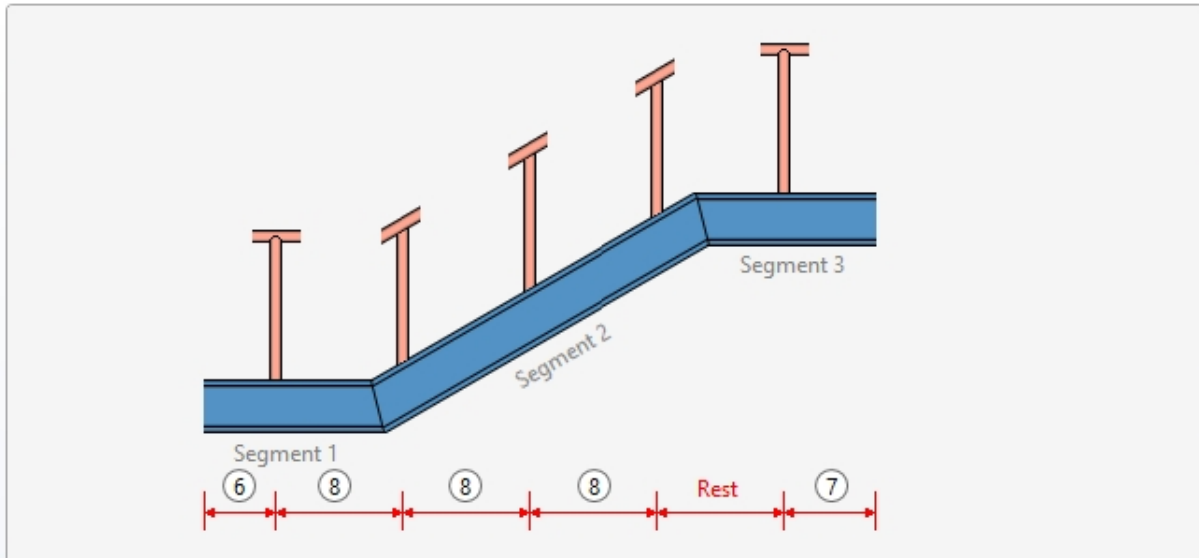

- Distribution of posts

- Evenly, with max. dist.
- Evenly, with number of posts
- Fixed distance, with rest
 - Patch at start
 - Patch at end
 - Distribute patch at both ends

Distance:

Number:

Individual 

- Reference for distances

- Post axis - Post axis
- Clear width

- Offset



(4) Corner distance: *

(5) Transition distance: *

(6) Start distance: 

(7) End distance: 

- Create which posts?

- Create start post
- Create end posts
- Create corner posts 
- Create transition posts 

- Reference for post distribution

- By segments
- Across complete walking distance

Evenly, with number of posts

Here, the calculation length will be divided by the number of posts, with regard to the axis. The value in the **Distance** field as well as the Transition distance (Dimension 5) will not be considered.

Fixed distance, with rest / Position of patches

If you select this option, you need to check whether the remaining rests (patches) are to be located at the start, at the end or on both sides. It is therefore recommended to use "virtual" vertical auxiliary lines during the construction process. For if the railing posts are to be located below one another after completion of the construction, this can be achieved easiest with this option. This means that the specified dimensions will only be used for the active flight of stairs (walking line). In the sketch you can see that the flight of stairs 1 places Dimension 6 at the bottom right (at the start), and Dimension 7 at the left. When you activate the flight of stairs 2, Dimension 6 will be located on the left, and Dimension 7 on the right. This should be taken into account to ensure that the correct distances will be entered. Dimension 5 will not be considered.

When selecting the beams, please note that HiCAD interprets the first selected beam as the start, which the later partitioning of the railing will be based on (fixed distance with rest at the start or end). In practice, engineers mostly use an upstairs walking direction as an orientation.

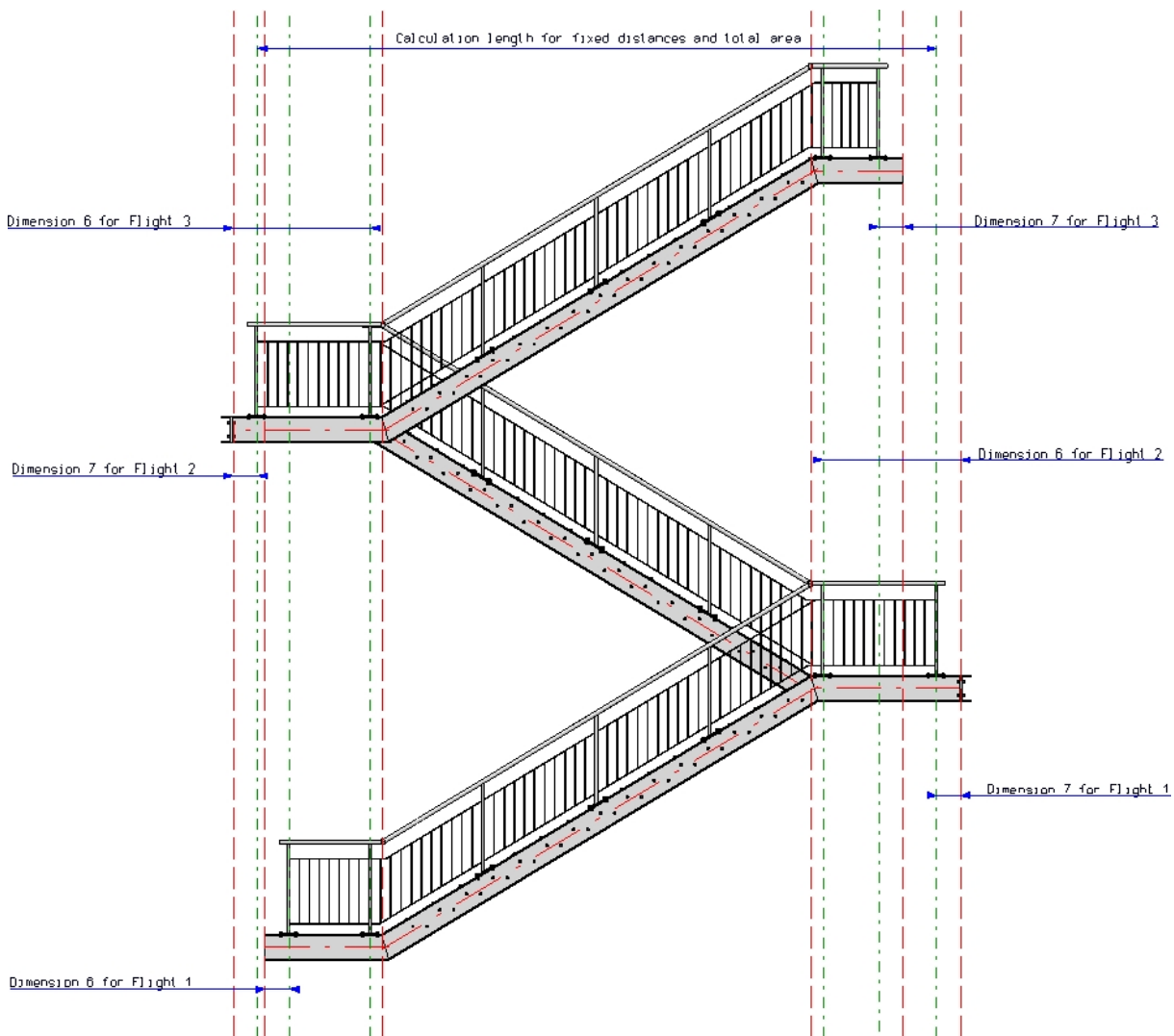



The present example consists of 3 staircase sections (Flight1 to 3). For each flight, the railing will be created separately for the right and for the left stair stringer. This means that railing creation in this example will consist of 6 steps.

The railing creation begins on the left stringer of the 2nd staircase, which is the staircase with the shortest flight. The post distances of the corresponding railing are to be used for all other railings. After creation of the first railing, all other railings can be derived very easily from its data.

Step 1: Railing for Staircase 2, left stringer

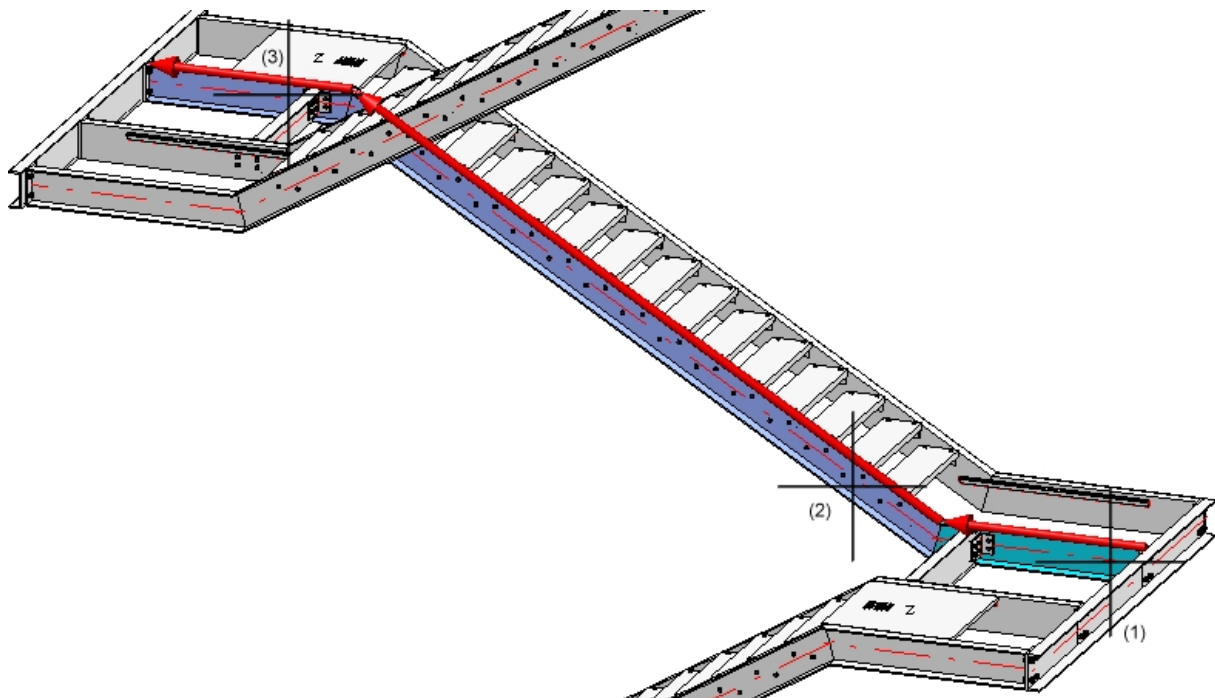
1. Call the Railing Configurator. Select beams (1) to (3), so that the walking line will be displayed as shown below. End the selection by pressing the middle mouse button.



2. As the ISD default settings with the exception of the post configuration will be used in this example, load these settings via the Favourites management .
3. Now change the parameters as follows:

- **Offset**

The railing is to be placed in a centred position onto the stringer, i.e. the walking line must be displaced. For this to happen, open the **Walking line** tab and enter the value 0 in the **Offset** input field. In the preview you can see that the walking line is now located in the centre of the upper beam side.

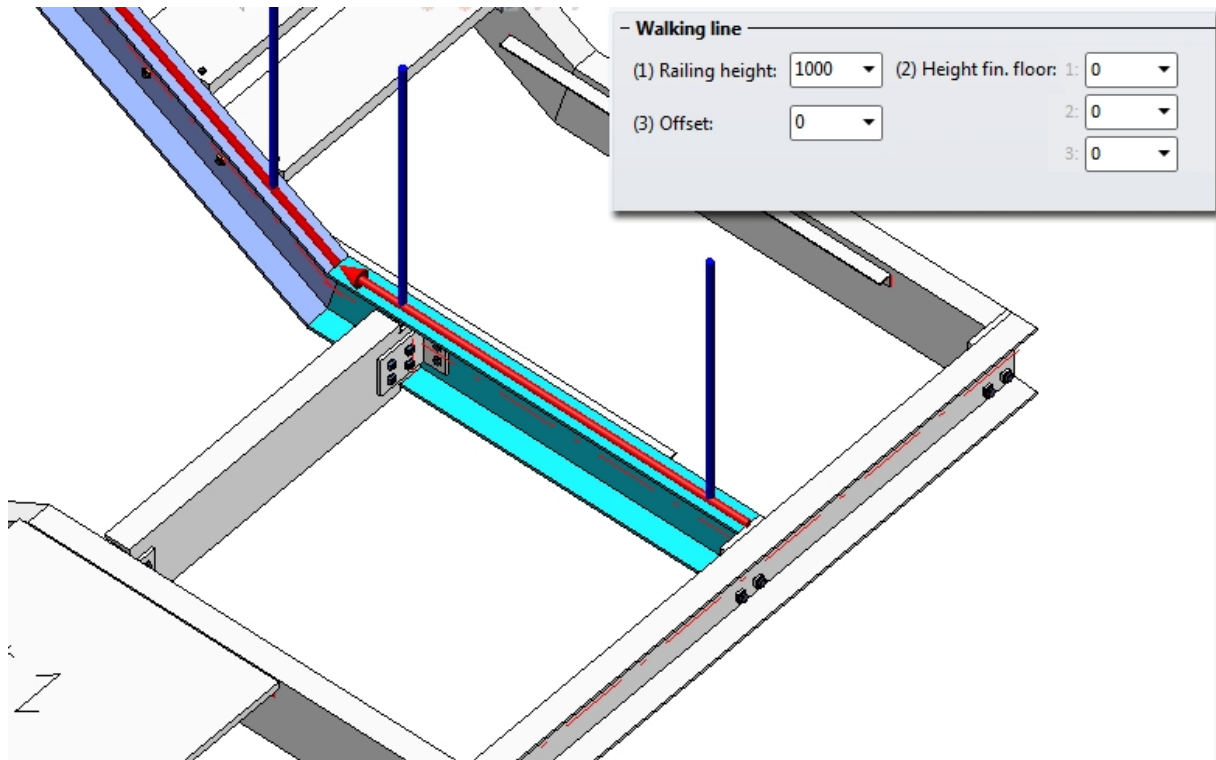

- **Start distance (6) and End distance (7)**

In this example, the start distance and the end distance are to be equal. Select 1460. The reason for this value is as follows: The length of the beam is 1585; for the mounting of the posts to the substructure you use the ISD default settings, i.e. a base plate with a length of 200 on which the post stands with a centred position (i.e. the distance of the post axis to the edge of the base plate is 100). To achieve a proper fixing of the plate, a distance of the base plate to the beam end of 25 must be taken into account. The final result is a start/end distance of $1585 - 100 - 25 = 1460$.

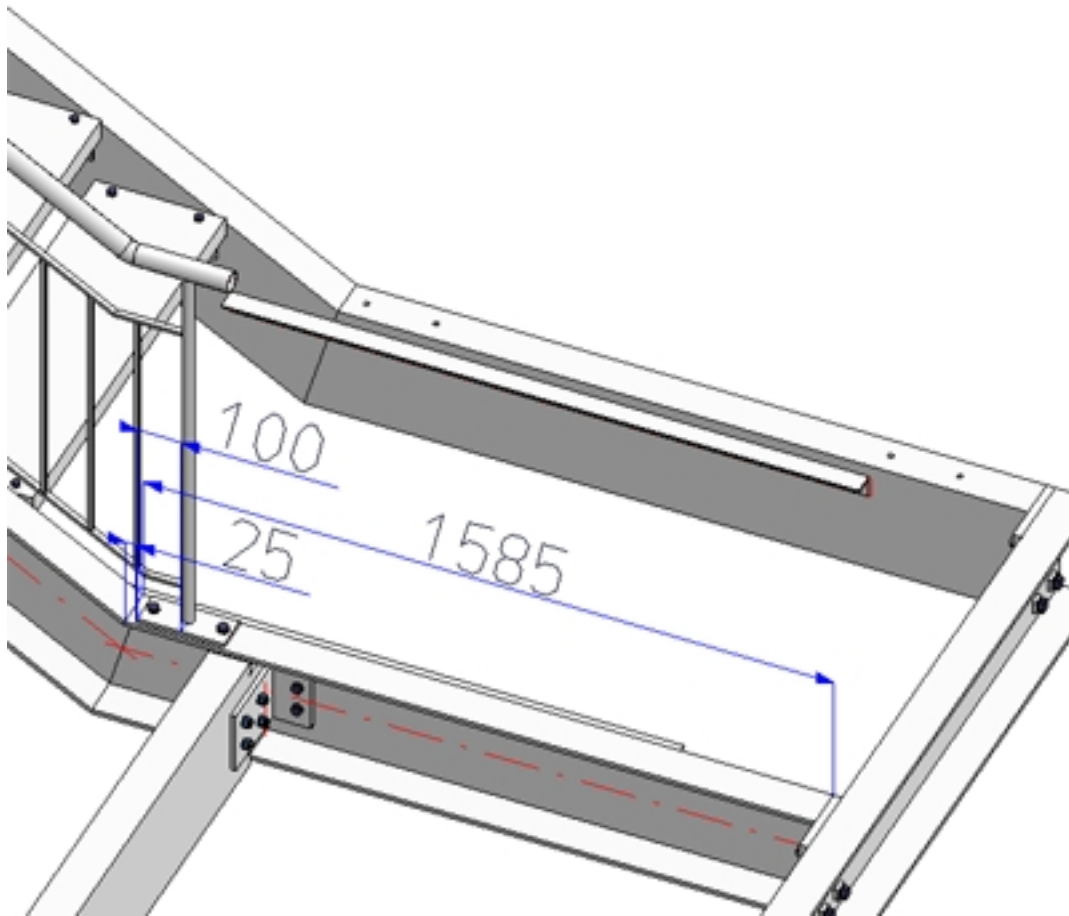

- **Post distribution**
Apply the following settings:

The diagram illustrates a staircase railing with three segments: Segment 1 (horizontal), Segment 2 (inclined), and Segment 3 (horizontal). Posts are shown at the start, end, and corners. A dimension line below the railing shows distances: 6, 8, 8, 8, 8, 7.

- Distribution of posts

- Evenly, with max. dist.
- Evenly, with number of posts
- Fixed distance, with rest
 - Patch at start
 - Patch at end
 - Distribute patch at both ends

Distance:

Number:

Individual

- Create which posts?

- Create start post
- Create end posts
- Create corner posts
- Create transition posts

- Reference for post distribution

- By segments
- Across complete walking distance

- Reference for distances

- Post axis - Post axis
- Clear width

- Offset

- (4) Corner distance:
- (5) Transition distance:
- (6) Start distance:
- (7) End distance:

4. Specify the components and connections.

Start posts, Intermediate posts, End posts All posts equal

Lateral offset to handrail: 0

- Post

Variant: Post from standard beam

Post: Pipe EN 10220 48.3x2.6 - S235JRH

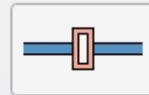
 Beam orientation*Handrail***- Handrail**

Variant: Handrail from standard profile

Excess length on first post: 100

Excess length on second post: 100

Handrail: Pipe EN 10220 48.3x2.6 - S235JRH

 Beam orientation

Infill

- Infill, between posts
 Infill, continuous

- Infill

Variant: Vertical rods with cross-members

(1) Top: 150

(2) Bottom: 100

(1)+(2): Perpendicular to handrail

(3) Distance: 120

(4) Width: 1

Rod rotation angle: 0

Trim to post

Trim rods to cross-members

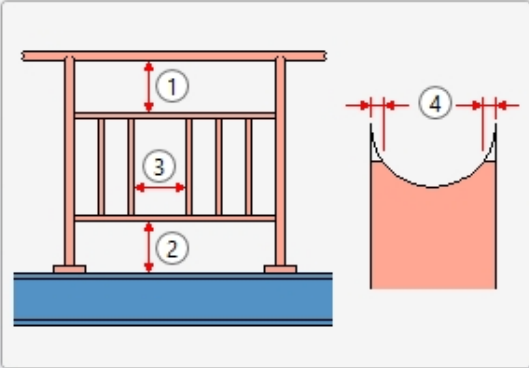

Cross-members: FI 30x6 - S235JR

Rods: FI 20x5 - S235JR

- Infill, corner

Corner infills can only be defined if:

1. the guideline has corners
2. no corner posts are created (see 'Post distribution')

- Infill, transition

Individual transition infill

Variant: Vertical rods with cross-members

Skirting boards

Variant: <Do not create>

- Assembling

Skirting boards, All
 Skirting boards, Platforms

Post - Substructure

Start post, individual

End post, individual

- Start, intermediate, end posts

Variant: Post connection, top

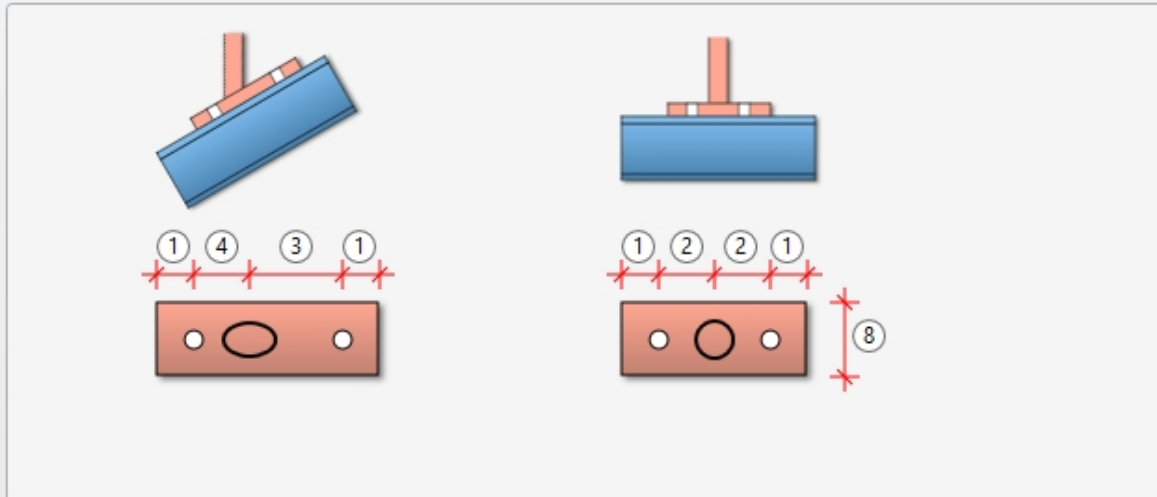

(1) 20

(2) 40

(3) 75

(4) 40

(8) 80

Fillet radius of corners: 0

90° rotated

With galvanising hole

Diameter: 20

Base plate: BI 14 - S235JR

Boltings: DIN EN 14399-3-M12-8.8

- Stiffeners

None One-sided Double-sided

BI 10 - S235JR, Width=Automatic

- Corner post (on the 'Post distribution' tab, activate 'Create corner posts checkbox')

Variant: <Do not create>

Post - Handrail

All connections equal

- Post - Handrail

Variant:

At lower edge of handrail

Width of obtuse end: ⓘ

- Corner post - Handrail (must have been activated on 'Post distribution' tab)

Variant:

Handrail - Handrail

- Handrail - Handrail

Variant:

Material of connecting pipe:

Type of connecting pipe:

Divide handrails

5. Confirm with **OK**.

All other railings can now be easily derived from the railing created in Step 1.

Step 2 - Staircase 1, left stringer

1. Call the Railing Configurator. Select the beams in such a way that the walking line will be displayed as shown below. End the selection by pressing the middle mouse button.

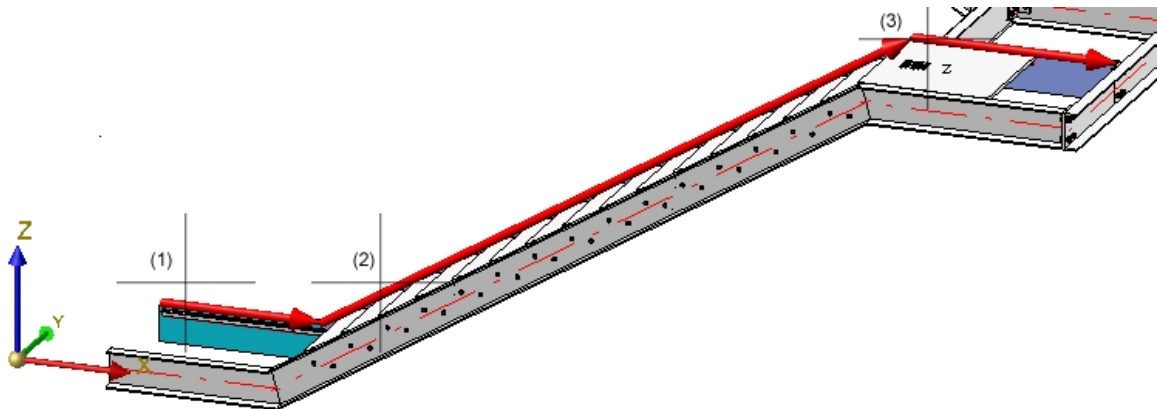

2. The railing parameters set during Step 1 still apply. As the beam types of all staircases are the same, you only need to change the start distance to 257,5. The End distance (Dimension 7) is identical to the Start distance

(Dimension 6) of the railing created in step 1, i.e. 1460.

The post distances of the railing is to be the same as the one for the railing created in Step 1, i.e. a fixed post distance must be selected. Click the  symbol to open the **Configure post distances** dialogue window. There, select the **Fixed distance, with rest** option. To apply the post distances of the first railing, right-click the **Distance**

field, select **Pick distance**, and then select the **Distance between 2 edges**  option in the menu. Then, identify two neighbouring posts of the first railing in the drawing (1202,5).

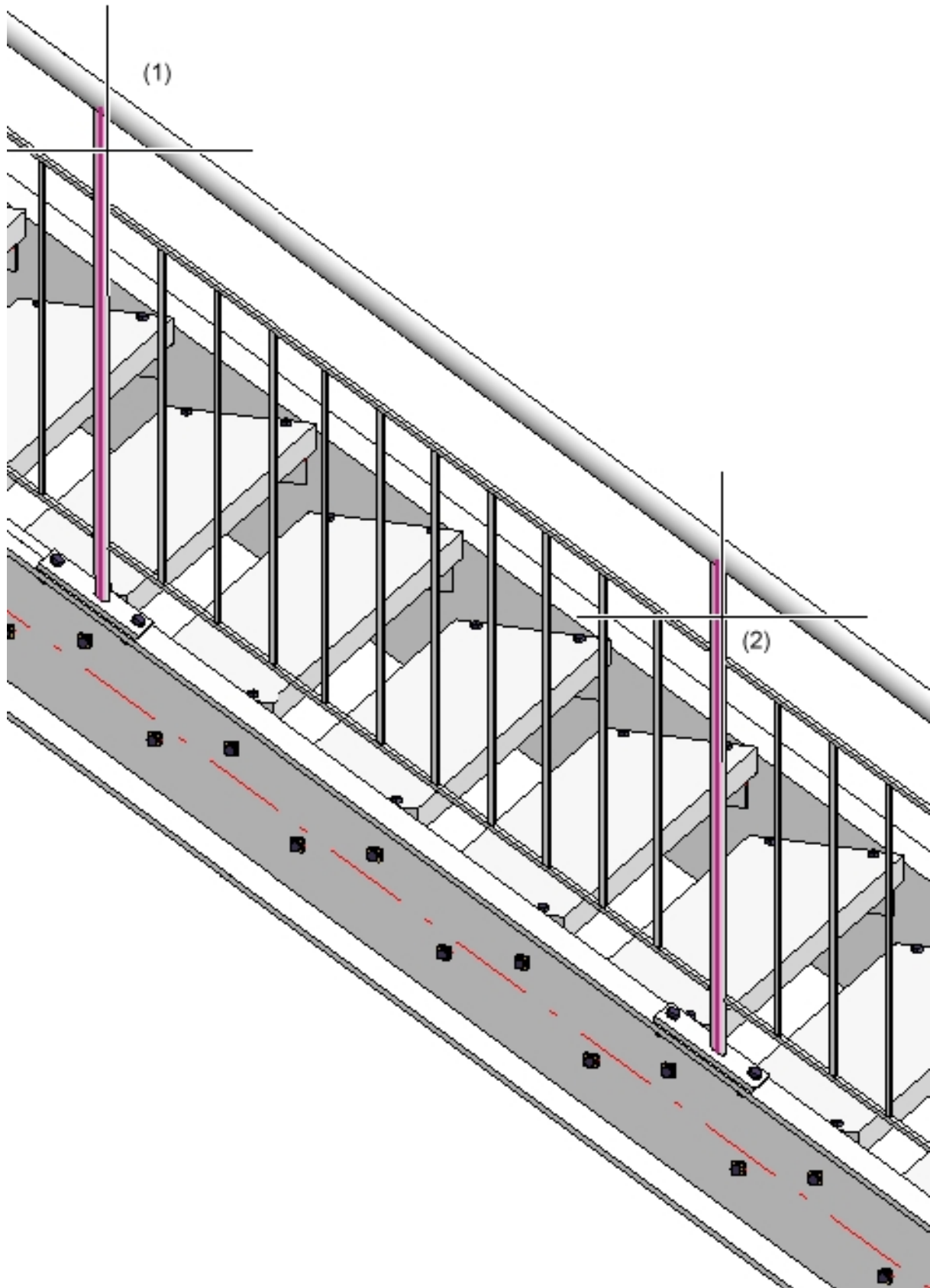

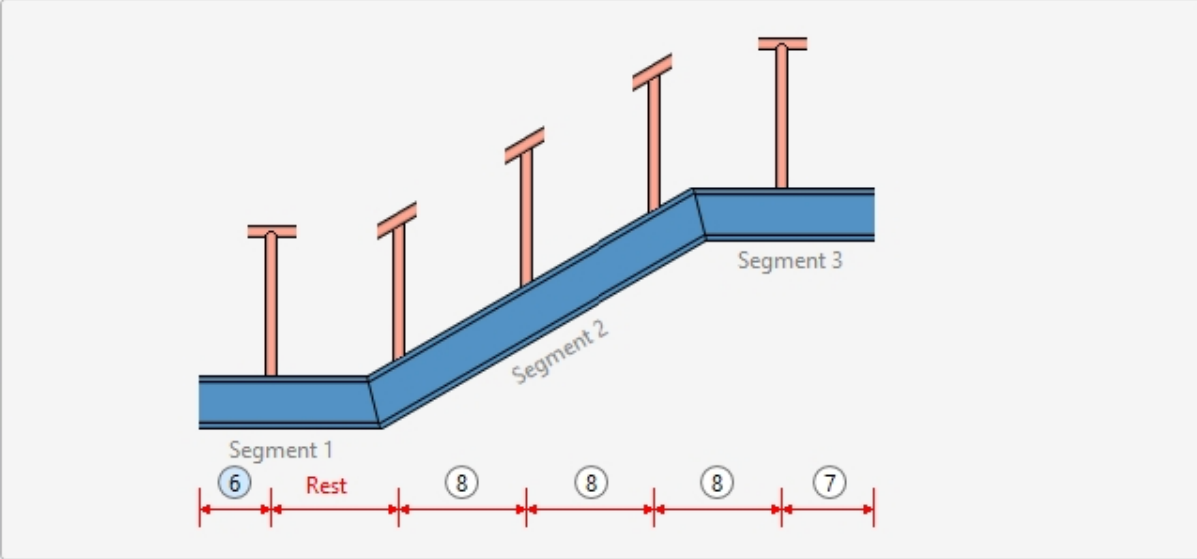

The diagram illustrates a railing configuration with three segments: Segment 1 (horizontal), Segment 2 (inclined), and Segment 3 (horizontal). Posts are shown at various intervals. Below the diagram, a distance scale shows segments of 6, Rest, 8, 8, 8, and 7 units.

- Distribution of posts



- Evenly, with max. dist.
- Evenly, with number of posts
- Fixed distance, with rest
 - Patch at start
 - Patch at end
 - Distribute patch at both ends

Distance:

Number:

Individual 

- Create which posts?

- Create start post
- Create end posts
- Create corner posts 
- Create transition posts 

- Reference for post distribution

- By segments
- Across complete walking distance



- Reference for distances



- Post axis - Post axis
- Clear width

- Offset

(4) Corner distance:

(5) Transition distance:

(6) Start distance:  

(7) End distance:  

3. Close the dialogue window with **OK**. Then, close the Railing Configurator with **OK**.

Step 3: Staircase 3, left stringer

1. Call the Railing Configurator again. Select the beams in such a way that the walking line will be displayed as shown below. End the selection by pressing the middle mouse button.

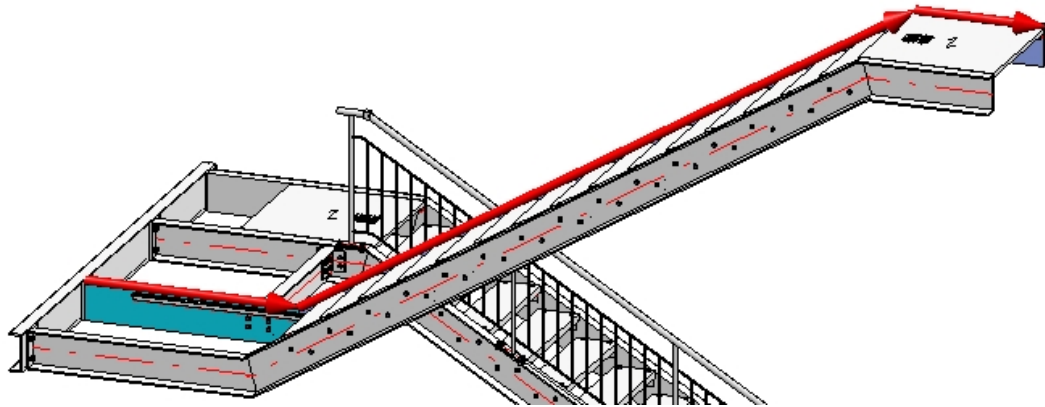

2. The railing parameters set during Step 2 still apply. Now we need to change the settings on the **Post distribution** tab.
3. The start of this railing is to be located at the same height as the end of the railing created in Step 1. This means that here, the start distance is identical to the end distance from Step 1, i.e. 1460.
4. The end distance is identical to the end distance of the railing created in Step 2, i.e. 257.5.
2. As the posts are to be positioned perpendicular above one another, the rest piece ("patch") need to be placed at the end here. Therefore, select the **Patch at end** option.
3. Close the dialogue window with **OK**. Then, close the Railing Configurator with **OK**.

Step 4: Staircase 2, right stringer

1. Call the Railing Configurator again. Select the beams in such a way that the walking line will be displayed as shown below. End the selection by pressing the middle mouse button.

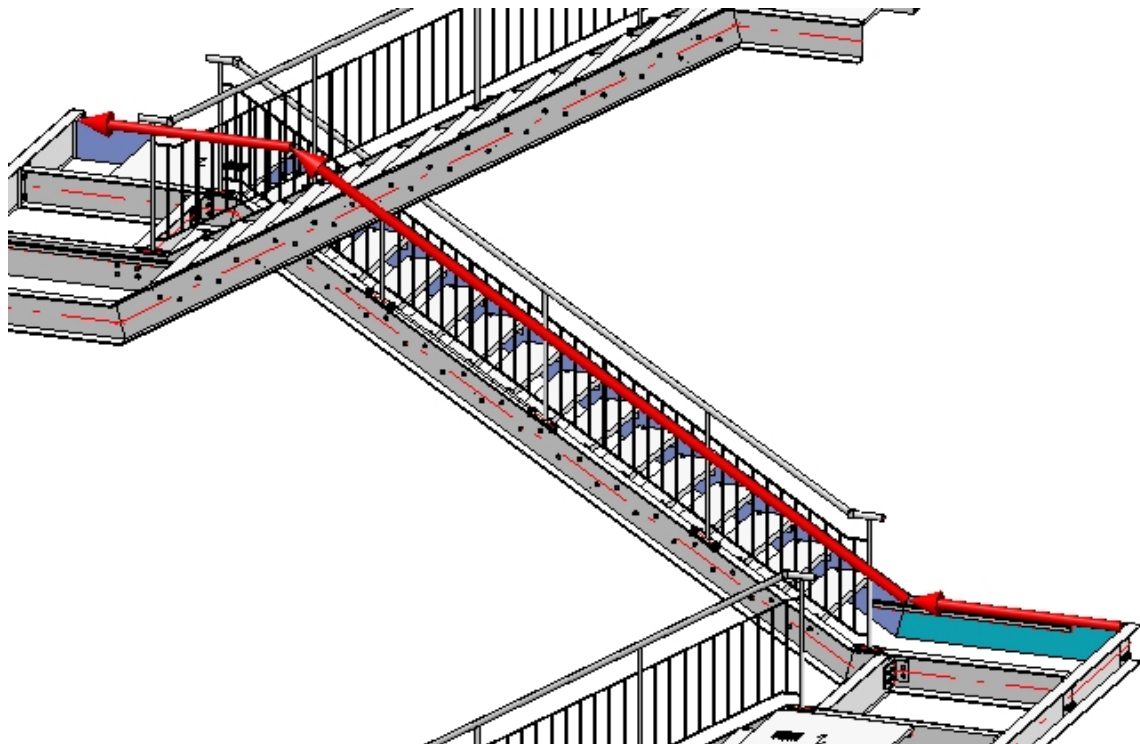

2. The railing parameters set during Step 3 still apply.
3. On the **Post distribution** tab, set the **Start distance** and the **End distance** to 257.5.

4. The displayed walking line is located on the inner side of the beam. However, the railing is to be placed in centred position.
5. As the posts are to be positioned perpendicular above one another, the rest piece ("patch") needs to be placed at the end here. This option is still active from the previous step.
2. Close the Railing Configurator with **OK**.

Step 5: Staircase 1, right stringer

1. Call the Railing Configurator again. Select the beams in such a way that the walking line will be displayed as shown below. End the selection by pressing the middle mouse button.

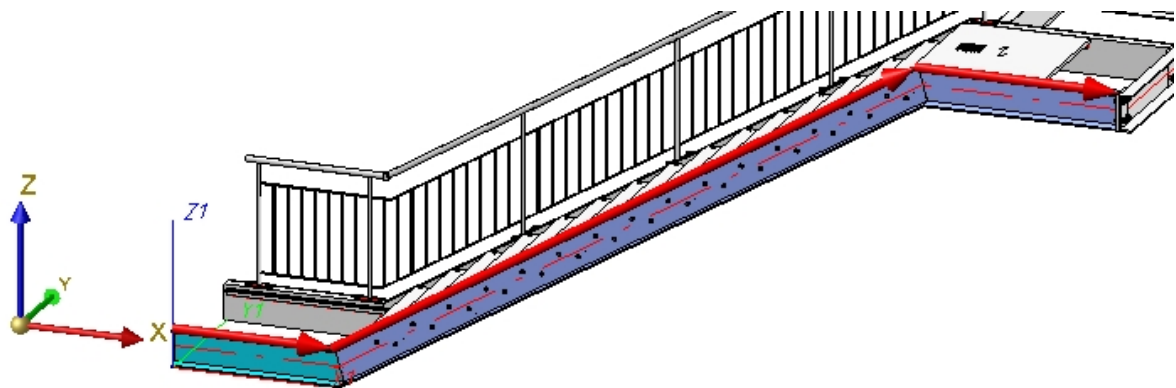

1. The railing parameters set during Step 4 still apply. Open the **Post distribution** tab.
2. The start distance is identical to that of the railing on the left stringer. The end distance is identical to that of the railing created in Step 4, i.e. in both cases 257,5 (value is still set). As the posts are all positioned perpendicular above one another, the rest piece ("patch") needs to be placed at the start here (as with the left stringer from Step 2). Therefore, select the **Patch at start** option.
3. Close the dialogue window with **OK**. Then, close the Railing Configurator with **OK**.

Step 6: Staircase 3, right stringer

1. Call the Railing Configurator again. Select the beams in such a way that the walking line will be displayed as shown below. End the selection by pressing the middle mouse button.

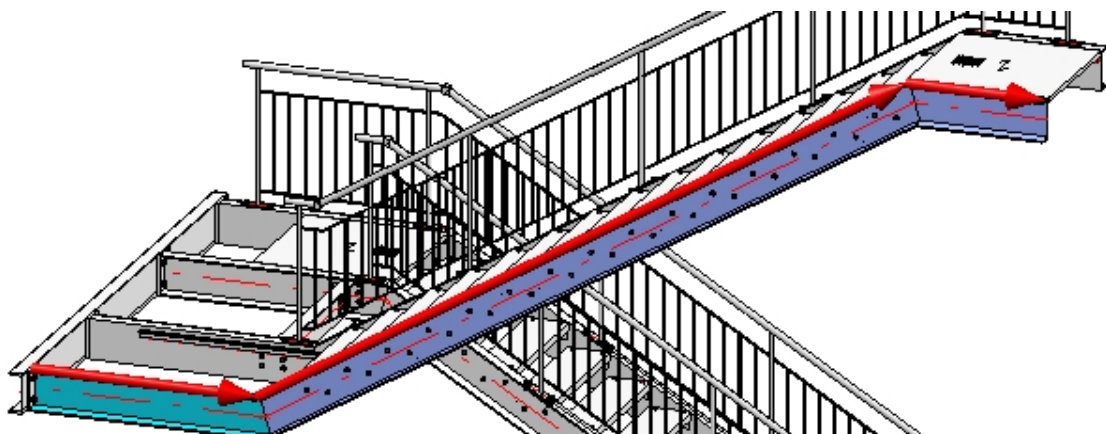

2. The railing parameters set during Step 5 still apply. Open the **Post distribution** tab.

3. The start distance is identical to the end distance of the railing created in Step 4, the end distance is identical to the end distance of the railing created in Step 3, i.e. in both cases 257,5 (value is still set). As the posts are all positioned perpendicular above one another, the rest piece ("patch") needs to be placed at the end here. Therefore, select the **Patch at start** option.
4. Close the dialogue window with **OK**. Then, close the Railing Configurator with **OK**.

Result, side view

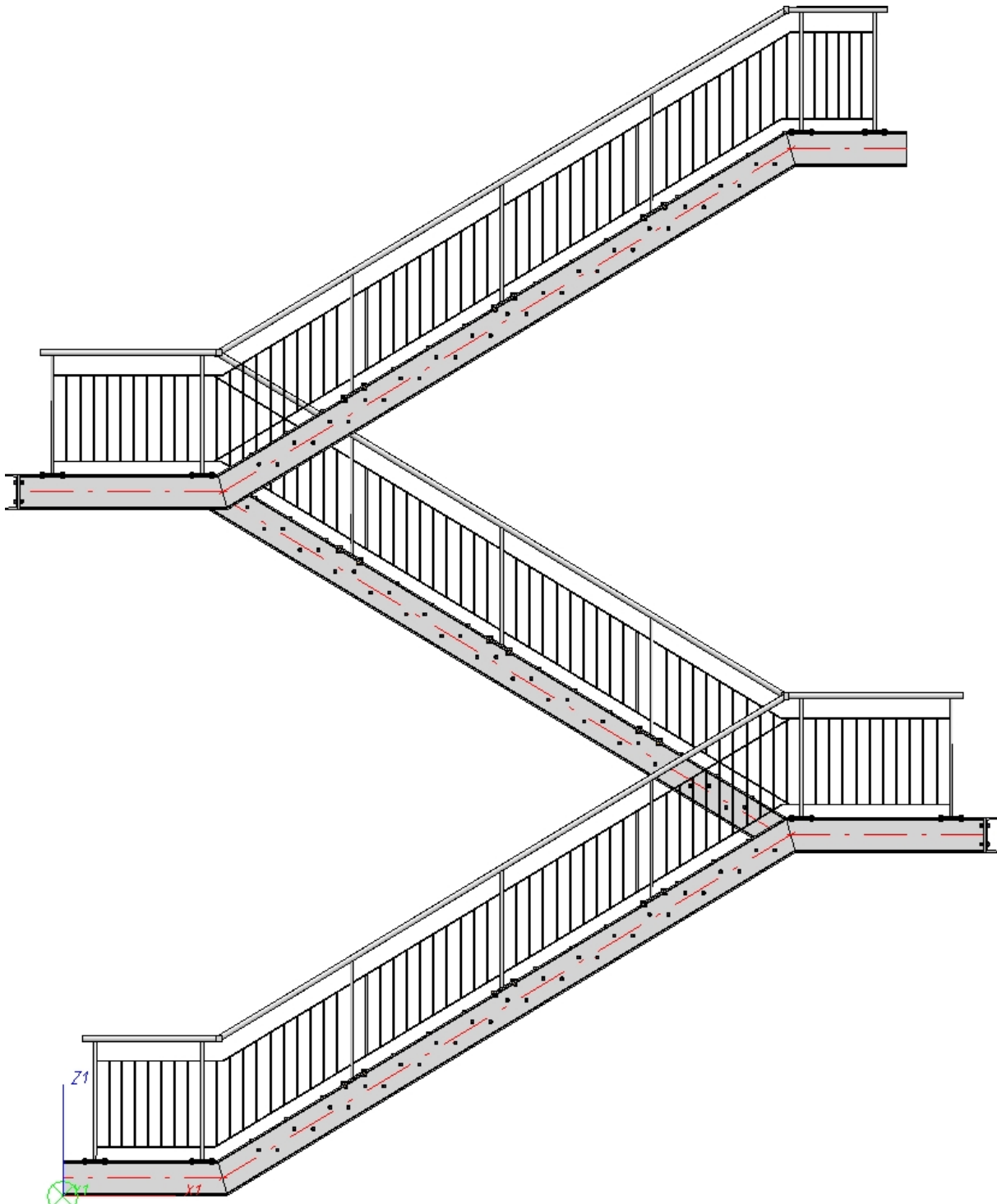

Railing Configurator - Railings along Edges

'Civil Engineering functions' docking window > Steel Engineering > Stairs + Railings > Railing > Railing Configurator (Railings along edges)

The **Railing Configurator** enables you to create individual railings along edges - for example, railings on balcony platforms (solid) or concrete stairs.

You can select edges of solids (body edges), of sketches or of 3-D sketches (part with free edges), or a combination of these edge types.

Important:

- The drawing must contain a main assembly. If this is not the case, a corresponding message will be displayed. Extensive information on main assemblies can be found in the topics Assemblies, Main Parts and Sub-Parts, Part Drawing or Assembly Drawing and Edit Part/Assembly Structure. If no main assembly exists, the following message will be displayed.

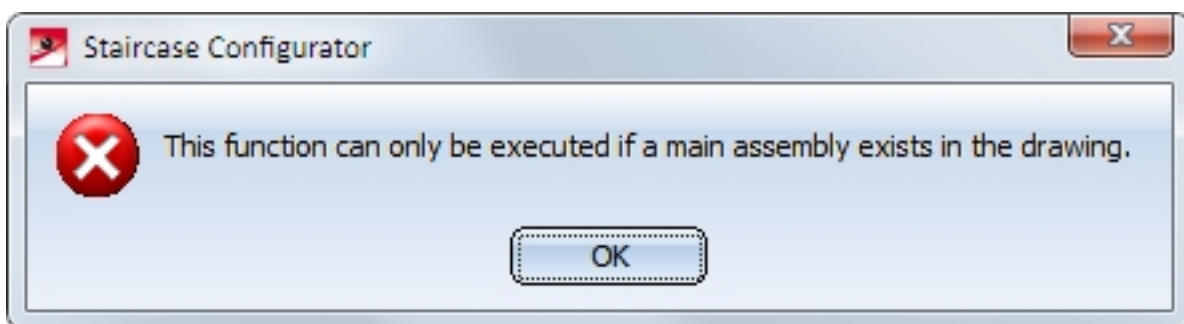

Select **Yes** if you want to create a new main assembly. In this way, railings along edges can be directly inserted.

- The edges along which the railing is to be placed must form one continuous "path", i.e. two successive edges must have an intersection point. Two successive edges must not run parallel to each other. The path of the edges must not form a loop.
- The Z-axis of the active coordinate system is the direction axis for the posts, which means that the beams must not run parallel to the Z-axis of the active coordinate system.
- The edges must be straight.

When you start the Railing Configurator, HiCAD will prompt you to identify, one after the other, the edges along which the railing is to be placed. The "path" that is defined by these beams is the "virtual guideline" determining the route of the railing. Posts, handrail, infill and knee rail of the railing will be located on c-edges running parallel to this guideline (the so-called "walking line"). When selecting the edges, please note that the first selected edge will for HiCAD be the start to which the later subdivision of the railing will refer (Fixed distance, with Patch at start or Patch at end).

The walking line and the walking direction are indicated by a red arrow. The height of the railing and also the fixing position refer to this walking line. The distribution of posts, too, will be visualized on the basis of the last selected settings. As soon as you change the settings in the Railing Configurator dialogue window, the preview will be updated.

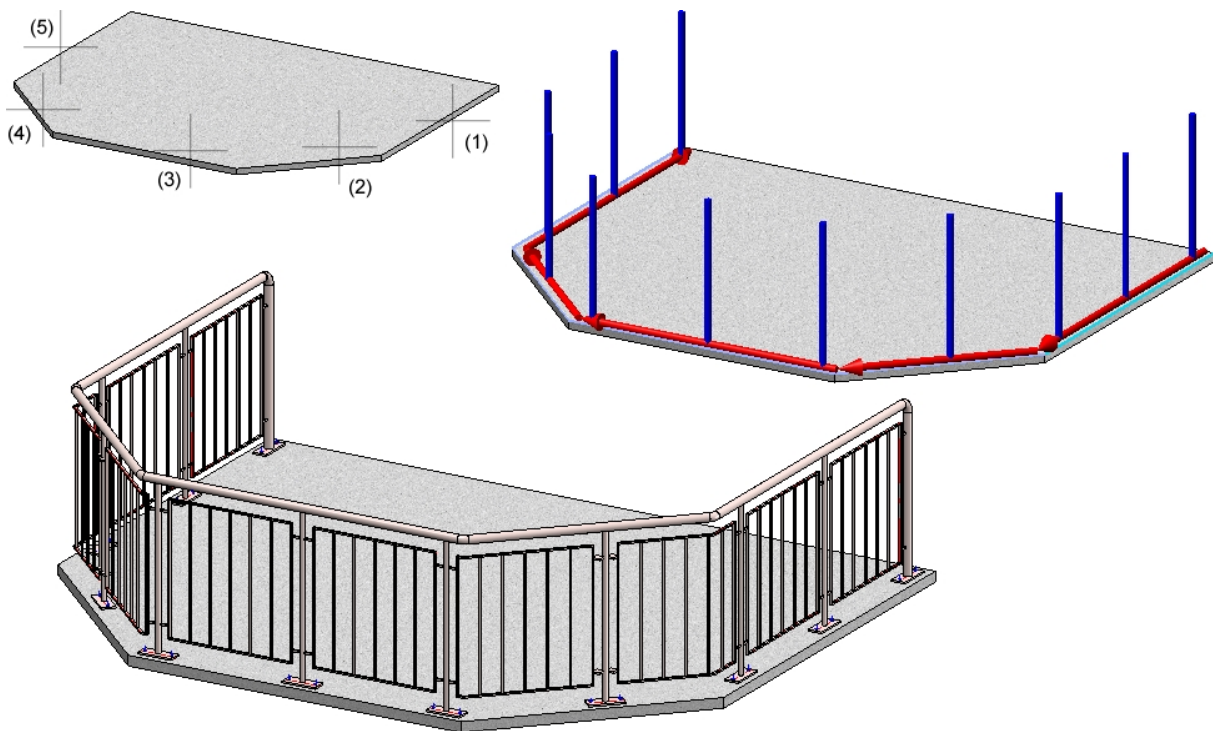

Top: Solid with selected edges; Bottom: Example of a railing

Press the middle mouse button to end identification of beams, which automatically opens the **Railing Configurator** dialogue window. The operation of the dialogue window is largely identical to that of the Railing Configurator (along beams) function, the only difference being the explanatory graphics in the **Walking line** and the **Post distribution** tab.

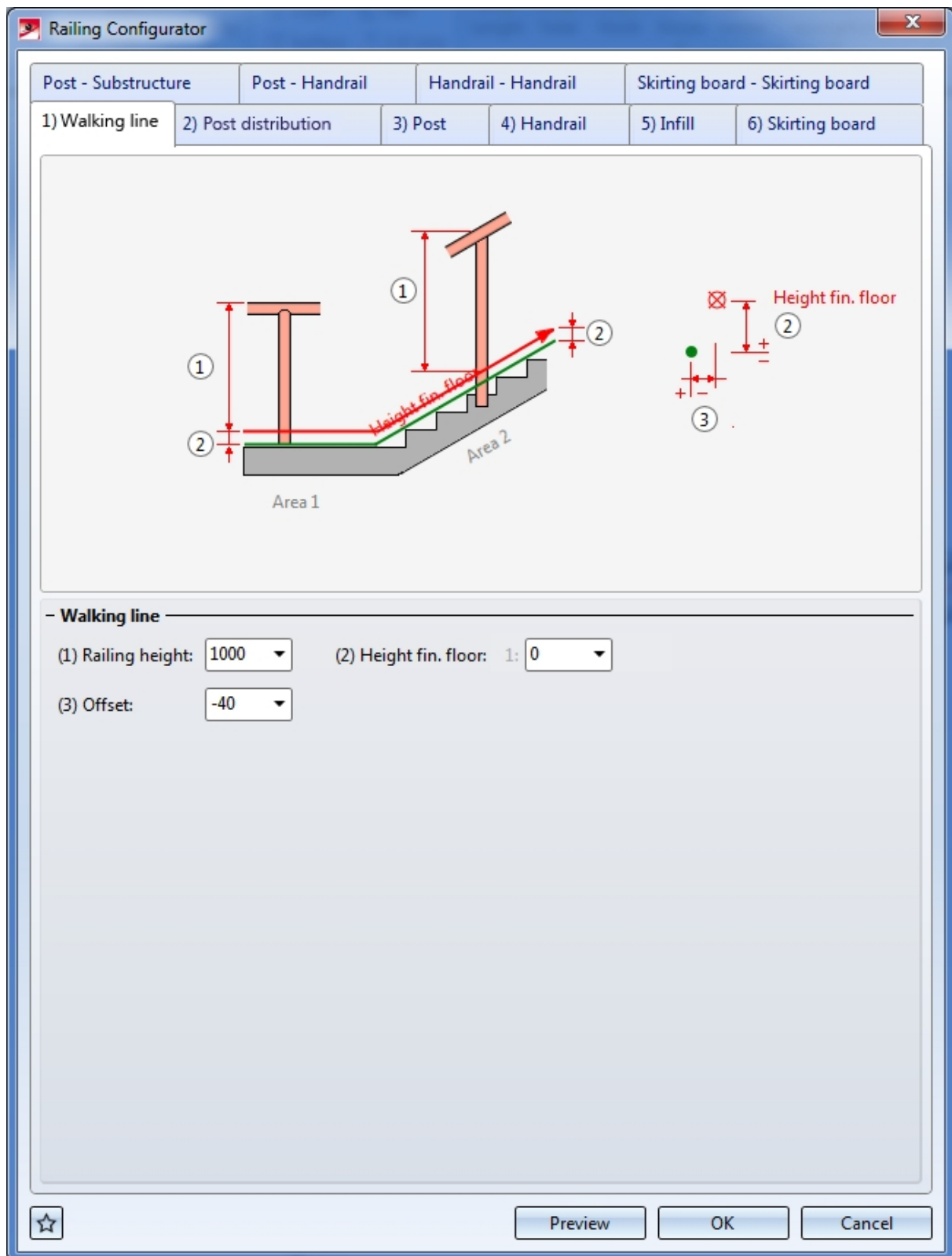
Railing Configurator (along edges) *dialogue window, Walking line tab*

Railing Configurator (along edges) dialogue window - Post distribution tab, By segments option

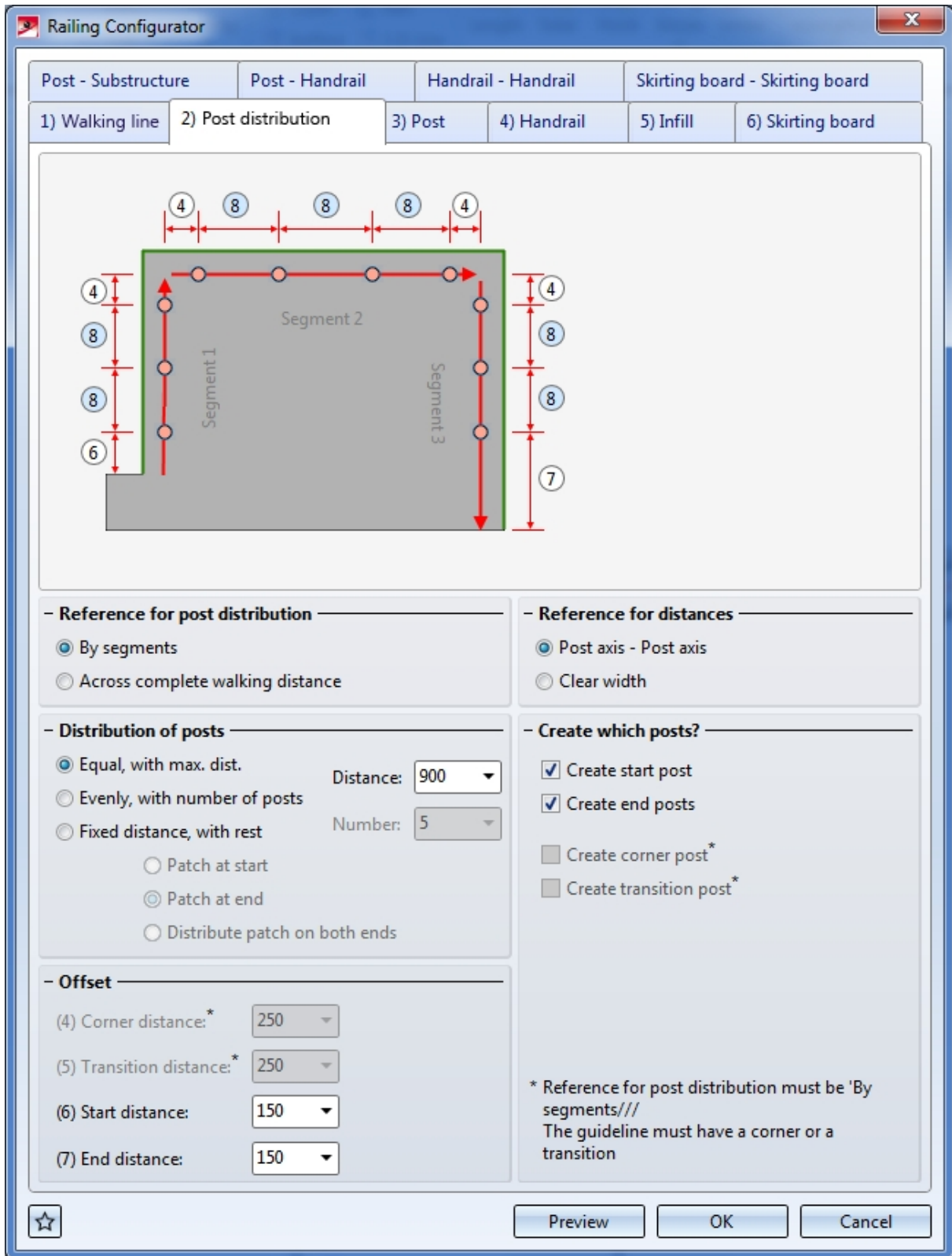

Railing Configurator (along edges) *dialogue window - Post distribution tab, Across complete walking distance option*

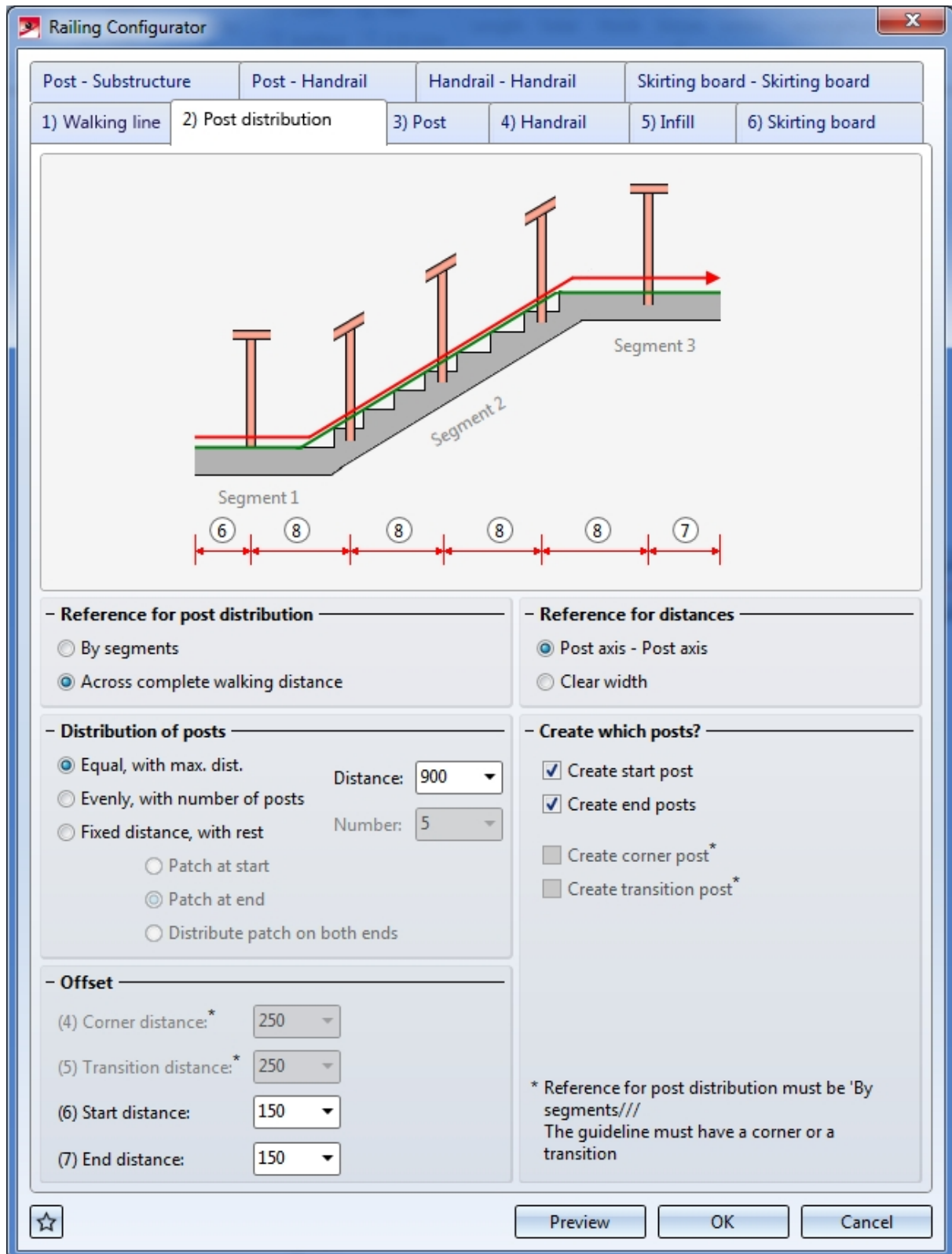

The dialogue window is identical to that of the **Railing Configurator - along beams** function, with the exception that the options and input fields for beam processing are not relevant here.

Click **OK** to start the generation of the railing. The status of the railing generation will be indicated by a progress bar. HiCAD creates a corresponding feature entry, **Railing along edges**.

HiCAD will create an assembly called **Railing**. This assembly is subdivided into further assemblies called **Segment**, which contain the railing elements of the individual beams.

The settings can be saved as Favourites and reused at any time. At the bottom left of the dialogue window, click the  symbol to activate a menu with Favourites functions. More information about Favourites can be found in the **Manage Favourites** topic of the **HiCAD Basics** Help.

While the window is open, you can display a **Preview** of the railing generated with the current settings by clicking the same-named button. You can use the zoom functions to enlarge or downsize the object on the screen.

Click **OK** to start the generation of the railing. The progress of the generation will be indicated in a progress bar.



Please note:

- It is also possible to create customer-specific Design Variants for the components. If you require further information, please contact our Consulting department.
- All settings made in the Railing Configurator dialogue window will be the new default settings when the configurator is called again.
- Please also read the information given in the topic Railing Configurator - Important Notes (3-D SE).
- For concrete stairs, it makes sense to use only one lateral anchor for each post.
- You can also create curved railings in one plane, i.e. the composite edge may also contain arcs.



Curved railing, created on the basis of arcs

Please note:

Even if you activate the **All posts equal** checkbox on the **Post** tab, the settings on the tabs **Post - Sub-structure** and **Post - Handrail** will not be considered for corner posts and transition posts! The connections on corner posts and transition posts must therefore be reworked manually.

Example - Railing with Individual Post Distribution

Civil Engineering functions docking window > Steel Engineering > Stairs + Railings > Railing > Railing Configurator (Railings along edges)

In this example the post distribution for the railing on a concrete staircase is to be customized.

The concrete staircase show below is to be used as the basis for the following steps.

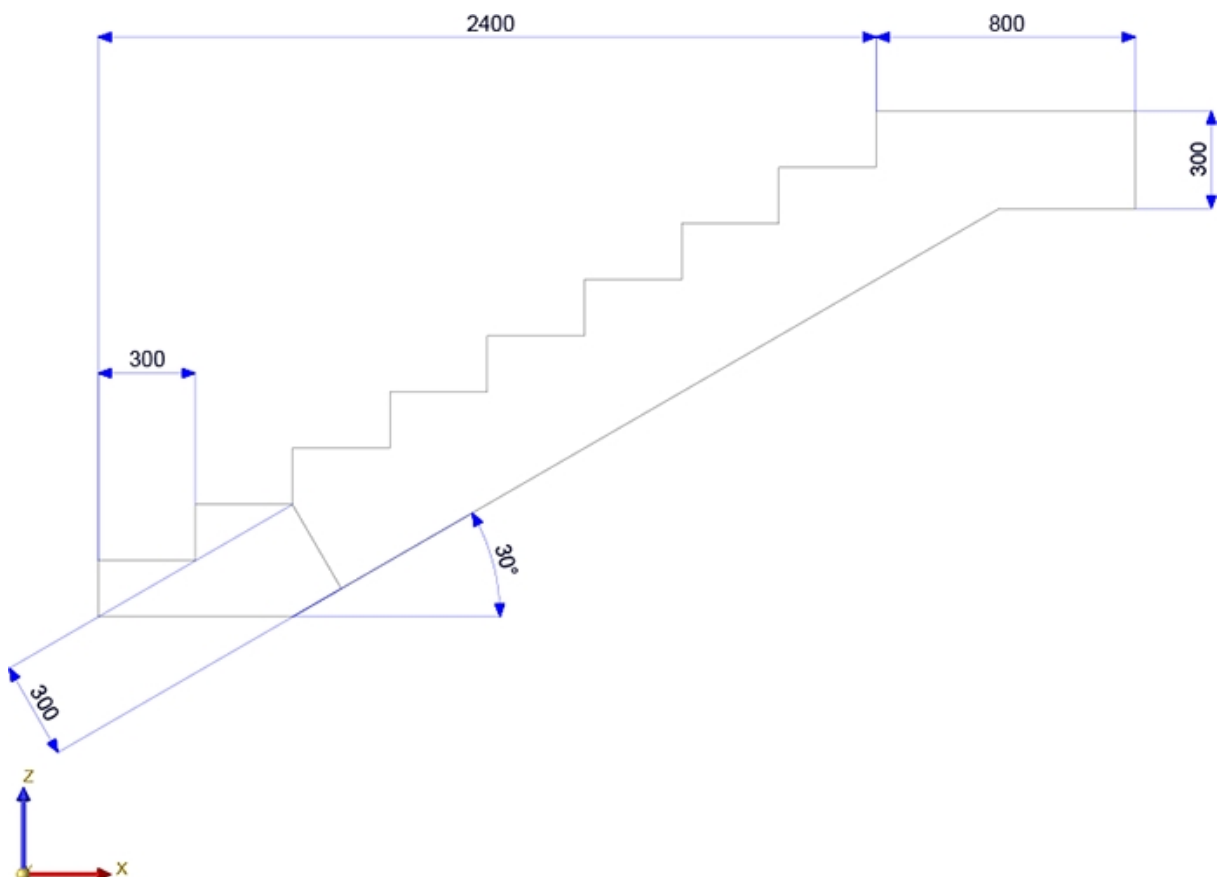
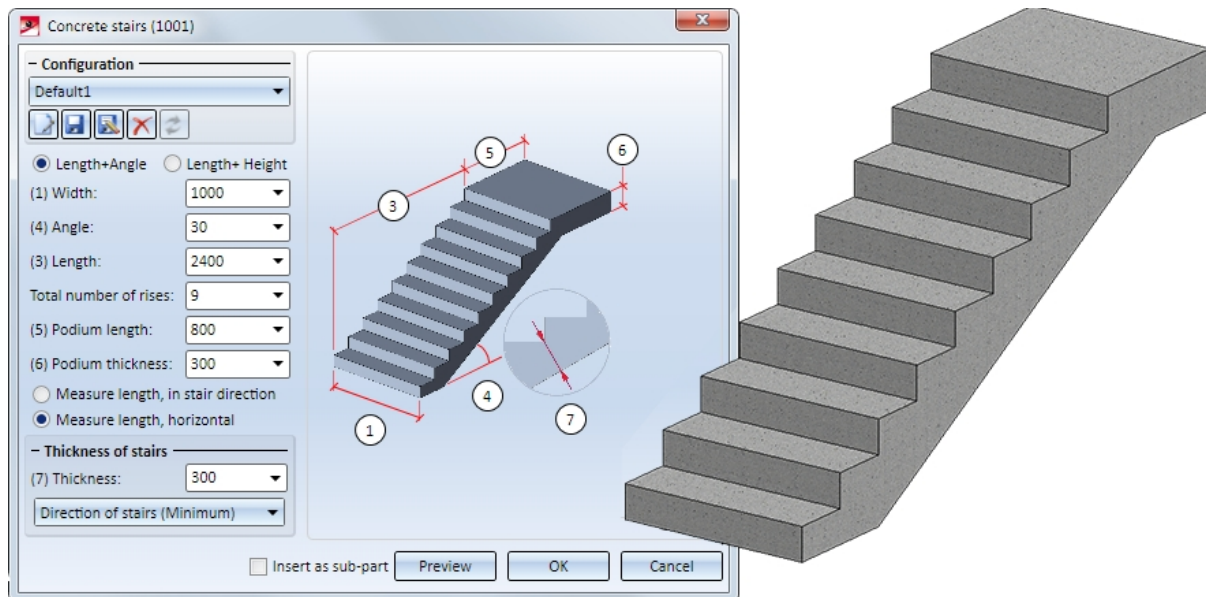

The railing is to be routed along the composite edge shown below (3-D sketch) that is defined via the points (1), (2) and (3):

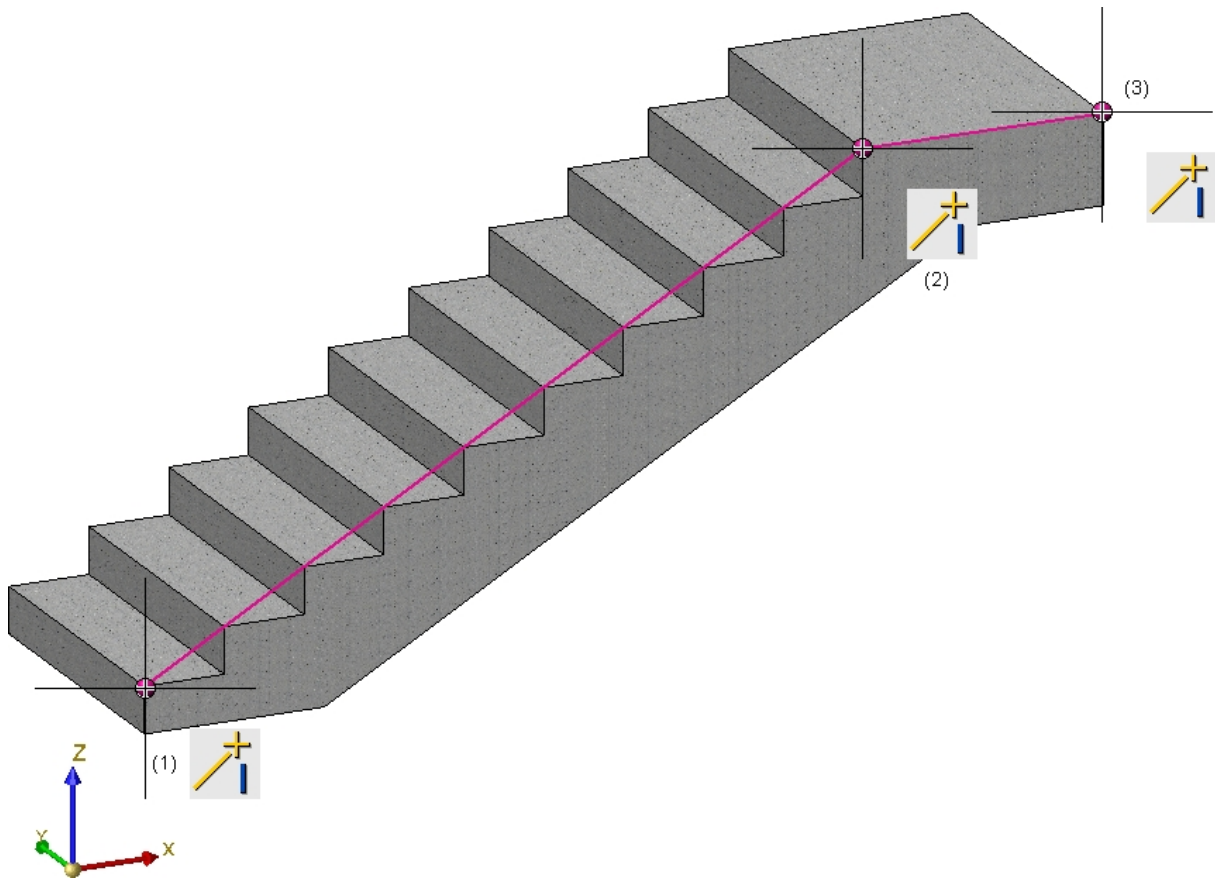

After calling the Railing Configurator (Railing along edges), identify both edges of the 3-D sketch. Then, press the middle mouse button to start the Railing Configurator. In this example we will use the ISD default settings, except for the Walking line, Post distribution, Infill and Post - Sub-structure tabs the settings of which are to be modified as shown below.

Post distribution

Post - Sub-structure	Post - Handrail	Handrail - Handrail	Skirting board - Skirting board
1) Walking line	2) Post distribution	3) Post	4) Handrail
		5) Infill	6) Skirting board

The diagram illustrates a railing system with three segments: Segment 1 (horizontal), Segment 2 (inclined), and Segment 3 (horizontal). Posts are distributed across the segments. A dimension line below the railing shows distances: 6, 8, 8, 8, Rest, 7.

- Distribution of posts

Evenly, with max. dist.

Evenly, with number of posts

Fixed distance, with rest

Patch at start

Patch at end

Distribute patch at both ends

Distance:

Number:

Individual Auto->Individual

- Reference for post distribution

By segments

Across complete walking distance

- Reference for distances

Post axis - Post axis

Clear width

- Create which posts?

Create start post

Create end posts

Create corner posts*

Create transition posts*

- Offset

(4) Corner distance:

(5) Transition distance:

(6) Start distance:

(7) End distance:

* Reference for post distribution must be 'By segments'. The guideline must have a corner or a transition. Connection to handrail and sub-structure must be constructed manually.

Infill

Post - Sub-structure	Post - Handrail	Handrail - Handrail	Skirting board - Skirting board		
1) Walking line	2) Post distribution	3) Post	4) Handrail	5) Infill	6) Skirting board

- Infill

Variant: Infill, kneerails

(1) Top: 250

(2) Bottom: 200

(3) Width: 1

Number of knee ra 3

Distribute evenly

Trim to post

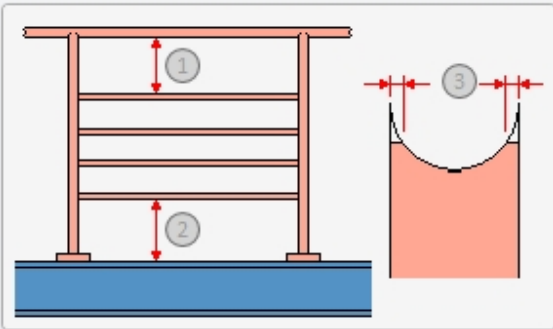

Knee rail: Pipe DIN 2448 13.5x2.9 - S235JRH

- Infill, corner

Corner infills can only be defined if:

1. the guideline has corners
2. no corner posts are created (see 'Post distribution')

- Infill, transition

Individual transition infill

Variant: Infill, kneerails

Post - Sub-structure

1) Walking line	2) Post distribution	3) Post	4) Handrail	5) Infill	6) Skirting board
-----------------	----------------------	---------	-------------	-----------	-------------------

Post - Sub-structure	Post - Handrail	Handrail - Handrail	Skirting board - Skirting board
----------------------	-----------------	---------------------	---------------------------------

- Post

Variant: Post connection, lateral

- Base plate

(8) Distance, plate centre: 170 Everywhere equal

Base plate: BI 14 - S235JR ⓘ

Boltings: DIN EN 14399-3-M12-8.8 ⓘ

(3) 30

(2) 80

(4) 65

- Connection Post-Base plate

Post mitre cut Distance element

Distance element: FI 60x12 - S235JR ⓘ

End cap, post: Endkappe-48.3x2.6 (Edelstahl) ⓘ

(7) Excess length of post: 10

Trim to post 1 ⓘ

After exiting the Railing Configurator the railing will be generated.

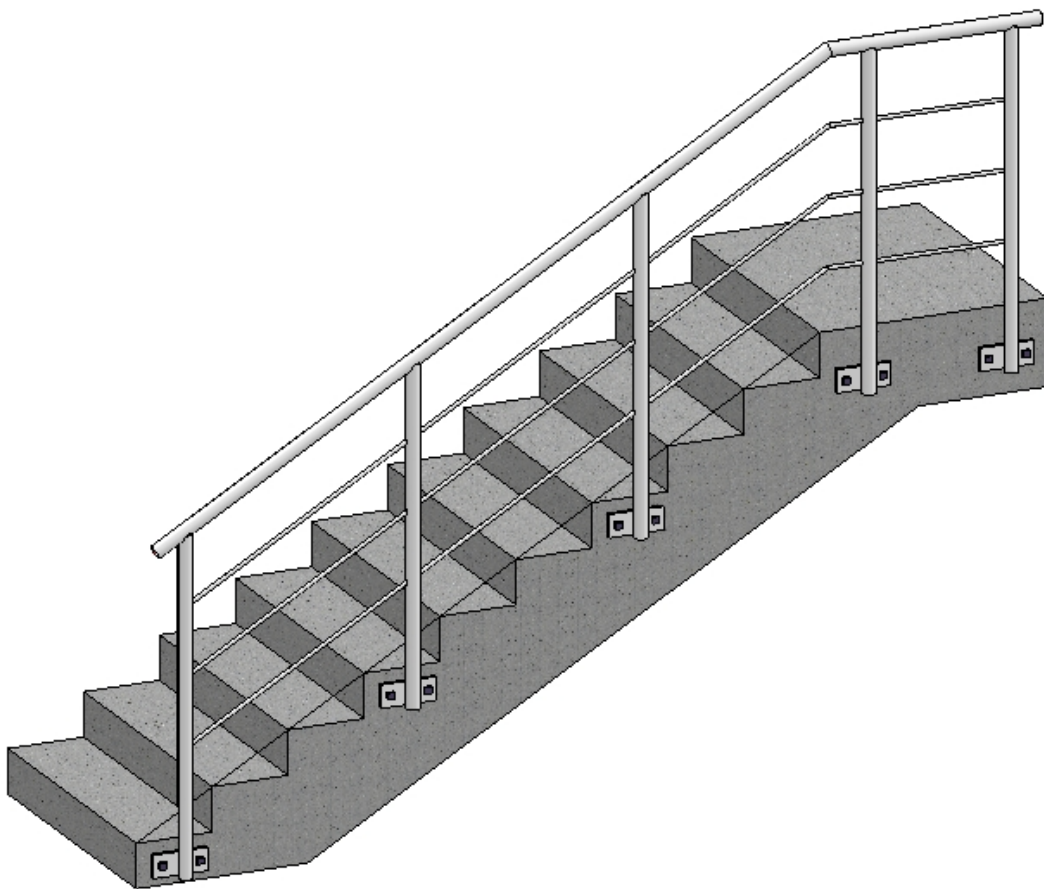

Now, the railing is to be processed and an individual post distribution is to be used. Start the Railing Configurator with a double-click on the corresponding Feature entry in the ICN.

After a click on the **Auto -> Individual** button on the **Post distribution** tab, the current posts and their distances will be shown on the right hand side of the window.

Example - Railing with Individual Post Distribution

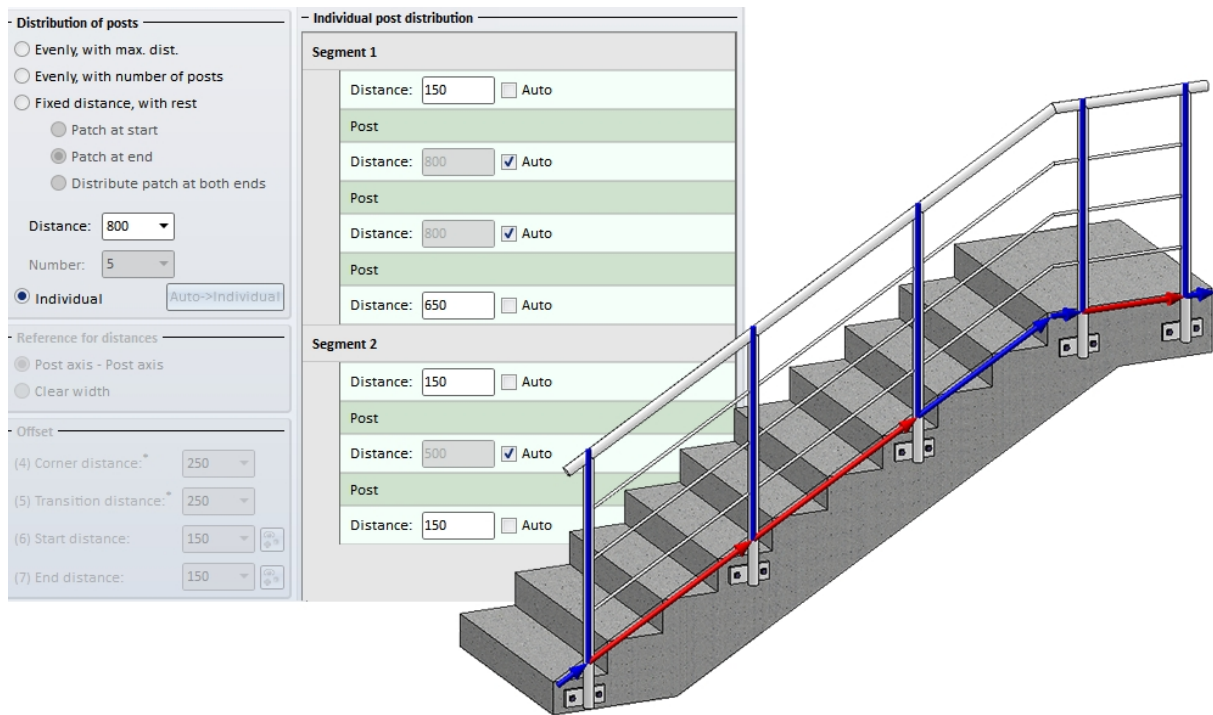

Now, the second Post of Segment 1 is to be moved via a point. To do this, click on the corresponding Post entry, then click on the **Move post, via point** button (1) and specify the point to which the post is to be moved (2). The preview (3) will then be updated.

Individual post distribution

Segment 1

Distance: 150 Auto

Post

Distance: 800 Auto

Post 

Distance: 800 Auto

Post

Distance: 650 Auto

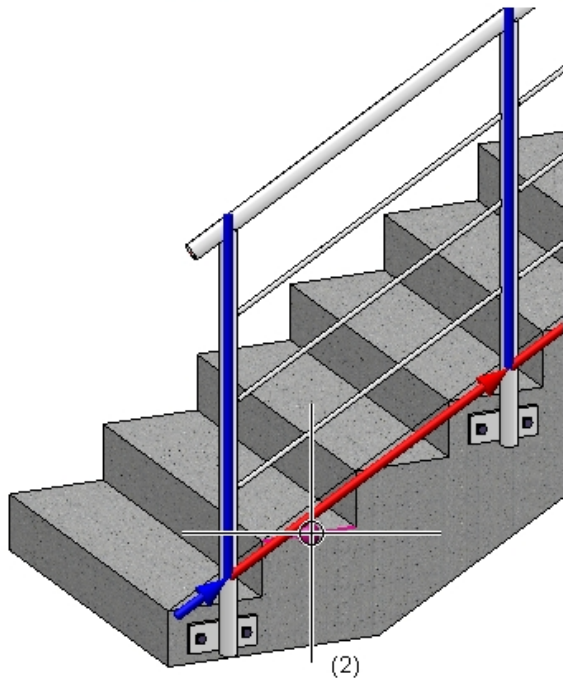
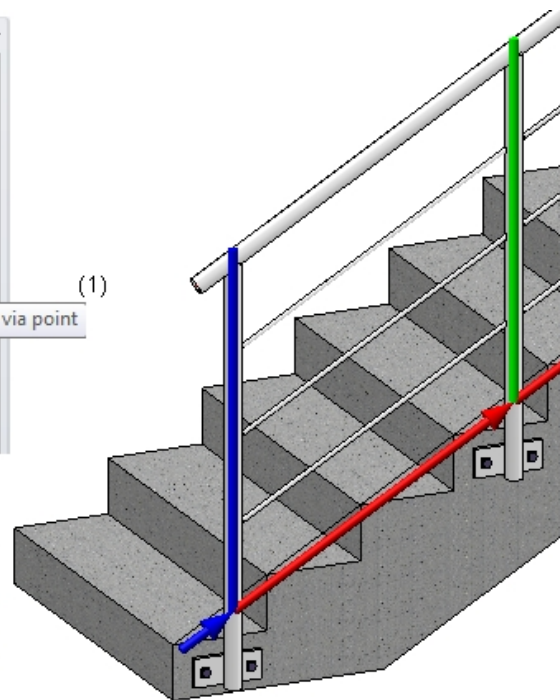

Individuelle Pfostenaufteilung

Segment 1

Distance: 150 Auto

Post

Distance: 250 Auto

Post

Distance: 1350 Auto

Post

Distance: 650 Auto

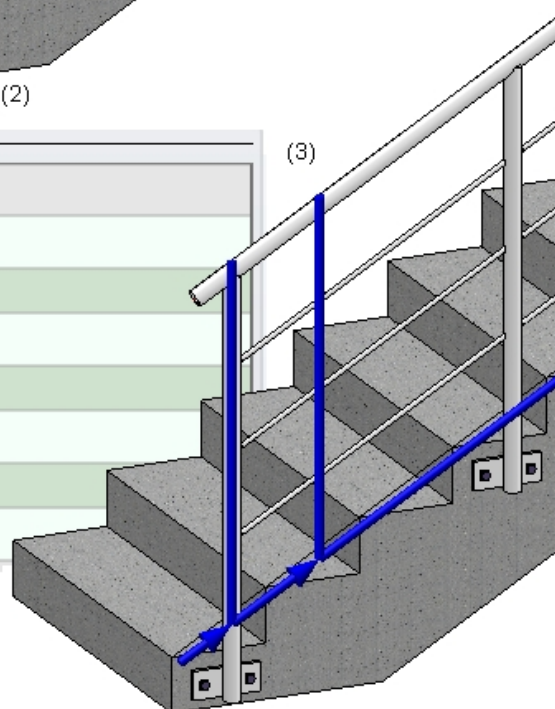

Proceed likewise to move the third Post of Segment 1. To do this, click on the corresponding Post entry again, then click on the **Move post, via point** button (1) and specify the point to which the post is to be moved (2). The preview (3) will then be updated.



Now, two new posts are to be inserted in Segment 1. To do this, click on the **New post, via point** button and specify the desired new point for the new post.



The **New post, via point** function remains active, allowing you to directly specify the position of the second new post.



Now, an even distribution of the posts in Segment 2 is to be determined: Activate the **Auto** checkboxes there.



Click **OK**. HiCAD will then generate the modified railing.

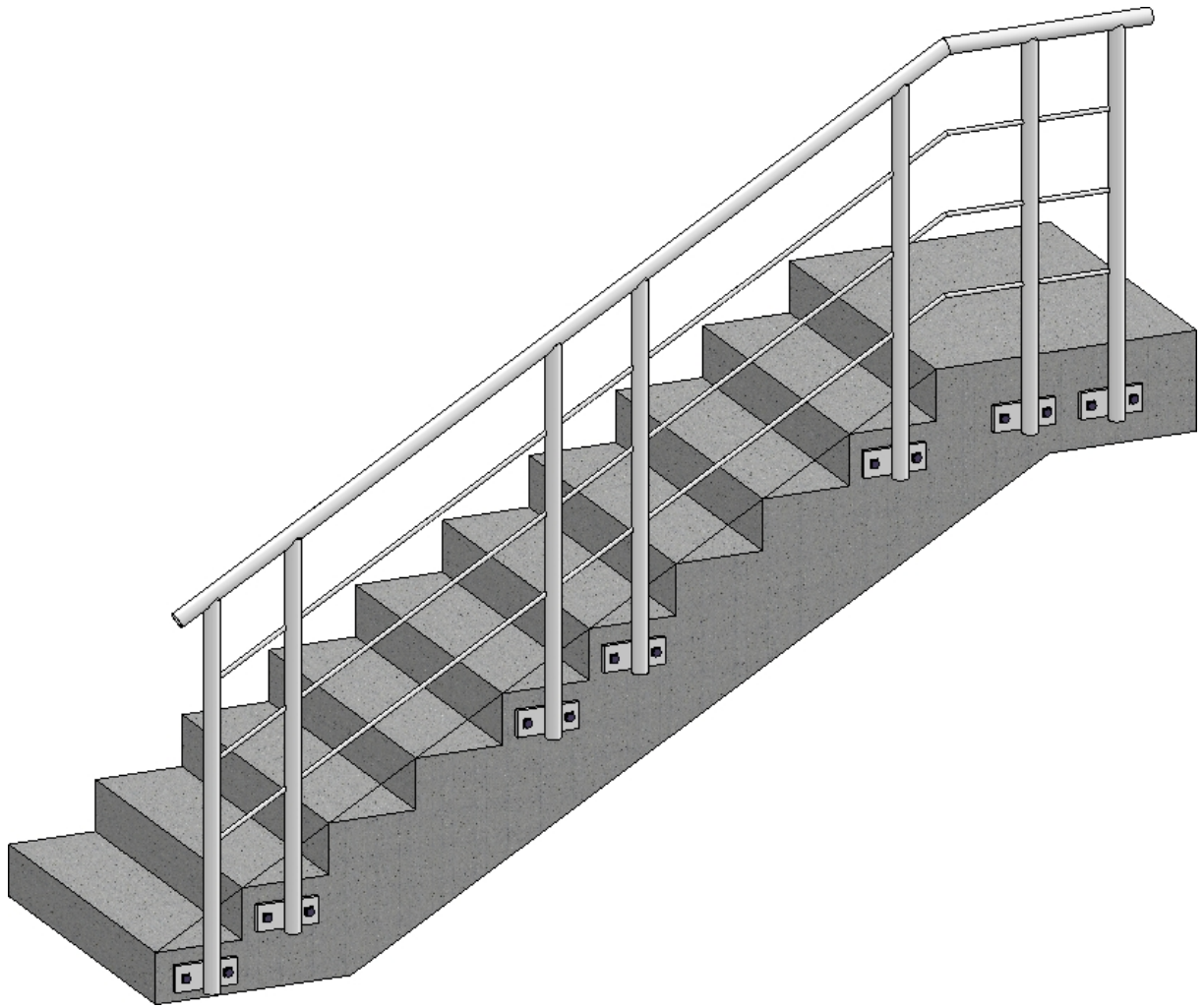

Legal notes

© 2026 ISD @ Software und Systeme GmbH. All rights reserved.

This User Guide and the software described herein are provided in conjunction with a license and may only be used or copied in accordance with the terms of the license. The contents of this User Guide solely serve the purpose of information; it may be modified without prior notice and may not be regarded as binding for the ISD Software und Systeme GmbH. The ISD Software und Systeme GmbH does not assume any responsibility for the correctness or accuracy of the information provided in this document. No part of this document may be reproduced, saved to databases or transferred in any other form without prior written permission by the ISD Software und Systeme GmbH, unless expressly allowed by virtue of the license agreement.

All mentioned products are trademarks or registered trademarks of their respective manufacturers and producers.



Your local contact

We attach great importance to the direct contact with our customers and partners, because only a lively dialogue and constant exchange with practice ensure application-oriented software development.

Feel free to contact us! Whether at our headquarter in Dortmund or at one of our branches and subsidiaries in your vicinity - we will be happy to answer all your questions about our products and services. We are looking forward to hearing from you!

Headquarter Dortmund

ISD Software und Systeme GmbH

Hauert 4

D-44227 Dortmund

Phone +49 231 9793-0

info@isdgroup.com

ISD locations worldwide at www.isdgroup.com